

BENSON VARIANTE ² RANGE BI DIRECTIONAL

NATURAL GAS (G20 I_{2H})
PROPANE GAS (G31 I_{3P})
TUBULAR HEATER

INSTALLATION COMMISSIONING

SERVICING

USER INSTRUCTIONS

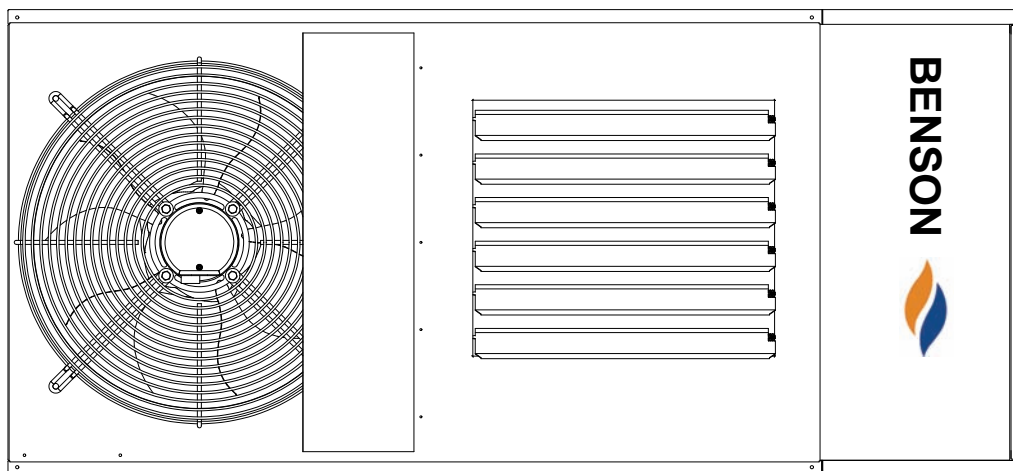

Issue 3
October 2007

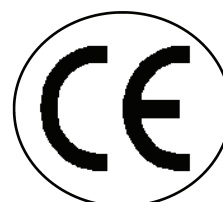

THIS MANUAL SHOULD BE LEFT WITH THE END USER .
TO ENSURE SERVICE AND MAINTENANCE INFORMATION IS AVAILABLE ON SITE

Section	Contents	Page No
1.0	Compliance Notices	4
1.1	Certificates of Conformity	5
1.2	General product Information	5
1.3	General Requirements	6
1.4	Delivery & Pre-installation Checks	6
1.5	Warranty	7
	Special risk areas	7
2.0	Installation	8
2.1	Installation Clearances and Mounting Heights	8
2.2	Heater Mounting	8
2.3	Warm Air Circulation	9
2.4	Air Supply	9
2.5	Flue Installation	13
2.6	Electrical Installation	17
2.7	Gas Installation	18
3.0	Commissioning	19
3.1	Electrical Pre tests	19
3.2	Gas pre tests	19
3.3	Ignition Sequence	20
3.4	Hand Over	21
4.0	Servicing	21
4.1	Servicing Procedure	21
5.0	Fault Diagnosis	23
6.0	Wiring Diagrams	25
7.0	Technical Data	30
7.1	Technical Data Common Information	30
	Pre Purge information	32
7.2	Technical Data Heater Specifications	33
8.0	Parts Listing	34
9.0	Dimensions	35

IMPORTANT NOTICE TO INSTALLERS

Installers should satisfy themselves that the gas pipework installation is carried out in accordance with all current legislation, Codes of Practice and recommendations .

Additionally it may be necessary to protect the gas valves which form part of the heater or burner assembly from potential pipe contamination particularly, but not exclusively , where copper gas pipework is used.

In instances where copper pipework is to be used for all or part of a gas pipework installation, including short length final connections then we advise that installers consult with gas supplier or provider and satisfy themselves what additional precautions may be necessary

Any reference made to Laws, Standards, Directives , Codes of Practice or other recommendations governing the application and installation of heating appliances and which may be referred to in Brochures, Specifications, Quotations, and Installation, Operation and Maintenance manuals is done so for information and guidance purposes only and should only be considered valid at the time of the publication. Benson Heating cannot be held responsible from any matters arising from the revision to or introduction of new Laws, Standards, Directives, Codes of Practice or other recommendations.

1.0 Compliance notices

The Benson Variante range of warm air heaters detailed herewith are manufactured by Benson Heating within a strictly controlled environment within the parameters of ISO9001: 2000

These instructions are only valid if the following country code is on the appliance

GB. IE. If this code is not present on the appliance, it is necessary to refer to the technical instructions which will provide the necessary information concerning the modification of then appliance to the conditions of use for the country.

The Benson Variante Range has been independently tested and assessed, and has been found to meet the Essential Requirements of the following European Directives.

Gas Appliance Directive (90 / 396 / EEC)

Machinery Directive (89 / 392 EEC)

Low Voltage Directive (73 / 23 / EEC & 93 / 68 / EEC)

Electromagnetic Compatibility Directive (98 / 336 / EEC & 91 / 31 / EEC)

Product Liability Directive 65 / 374 / EEC)

The manufacturer has taken reasonable and practical steps to ensure that Benson Variante Range of Heaters are safe and without risk when properly used. These heaters should therefore only be used in the manner and purpose for which they were intended, and in accordance with the recommendations detailed herewith.

The heaters have been designed, manufactured, assembled, inspected, and tested, with safety and quality in mind, there are certain basic precautions which the installer and user should be aware of, and they are strongly advised to read the appropriate sections of the information pack accompanying the heater, prior to installation or use.

Benson Heating supports all new products being supplied to their customers with a comprehensive information pack; this clearly defines mandatory instructions for the safe installation, use, and maintenance, of the Appliance (s).

Where proprietary items are incorporated into Benson Heating products, detailed information and instructions are also provided as part of the information pack.

It is the responsibility of the installer, owner, user, or hirer, of such products supplied by Benson Heating, to ensure that they are familiar with the appropriate information manuals, supplied by the manufacturer, and that they are suitably aware of the purpose of the manuals and the safety instructions. In addition, operators must be suitably trained in the use of the appliance so as to ensure its continued safe and efficient use.

Benson Heating has a commitment to continuous improvement, and therefore reserves the right to amend or change the specification of the Variante Heater range subject to agreement from The Notified Body.

Contained within the text of the manual, the words '**Caution**' and '**Warning**' are used to highlight certain points.

Caution is used when failure to follow or implement the instruction (s) can lead to premature failure or damage to the heater or its component parts.

Warning is used when failure to heed or implement the instruction (s) can lead to not only component damage, but also to a hazardous situation being created where there is a risk of personal injury.

The Benson Variante range of heaters conform to the following European Harmonised Standards.

BS EN 1020 Requirements for non domestic gas fired forced convection air heaters for space heating incorporating a fan to assist transportation of combustion air and/ or combustion products.

BS EN - ISO 12100-1:2003 &
BS EN - ISO 12100-2:2003
Safety of Machinery - Basic Concepts,
General Principles for Design
Part 1 & Part 2

BS EN 60204 - Part 1 : 1993
Safety of Machinery - Electrical Equipment
for Machines Specification for General
Requirements

BS EN 60335 - Part 1 : 1988
Safety of Household and Similar Electrical
Appliances General Requirements

BS EN 55014 - 1993
Limits and methods of measurement of radio
disturbance characteristics of electrical
motor-operated and thermal appliances for
household and similar purposes, electrical
tools and similar electric apparatus

BS EN 50165 - 1997
Electrical Equipment of non-electric heating
appliances for household and similar
purposes, safety requirements

The Benson Variante range of gas unit
heaters meet with the governments criteria in
respect of the Enhanced Capital Allowance
Scheme

1.1 Certificates of conformity

Declarations and Certificates are available
upon request from the Quality Control
Department at Benson Heating .

Notified Body PIN Reference is

063BQ5461

1.2 General product information

The Benson Bi Directional Variante range
includes for 4 model sizes with outputs from
72.0 kW to 144.0 kW,
Variante heaters are suitable for operation on
natural gas (G20) or LPG (Propane G31)

The Model Range is made up as follows

Model No	250	330	410	490
Output kW	72.0	96.0	120.0	144.0

Variante heaters have been approved for
alternative flue discharge arrangements
These are detailed in following page's
Cabinet

**Manufactured
from electro-
zinc coated
steel,
finished in a
durable stove
enamelled
polyester
powder paint.**

Heat Exchanger

**Manufactured
from aluminised
dimpled steel
tube formed into
a W shape to
give enhanced
efficiency .**

Flue / Combustion Air Spigot

Each heater is fitted with two spigots both of which are located to the rear of the appliance. One of the pair is for connection for the flue whilst the other is a screened combustion air intake.

WARNING

(SEE FLUE INSTALLATION 2.5 PAGE 14)

Burner

The induced draught multi in-shot burner assembly is manufactured from aluzinc coated steel and mounted to a common steel manifold which can be easily withdrawn through the burner access compartment.

Burner Control

The heaters are fitted with automatic ignition for all models within the range.

Exhaust Fan

Combustion gases are evacuated to atmosphere via an in built power flue venter fan which is safety interlocked to the gas valve via an air pressure proving device.

Air Movement Fan

VRABD are supplied with an Axial fan for free blowing applications.

Note

Neither asbestos nor soft soldered joints are used in the construction or manufacture of the Benson VRA range of Heaters.

The materials selected for use can withstand the mechanical, chemical, and thermal stresses which they will be subject to during foreseen normal use when installed in accordance with the manufacturers recommendations.

1.3 General Requirements

Caution

Before installation, check that the local distribution conditions, nature of gas and pressure, and the current state adjustment of the appliance are compatible.

Warning

Unauthorised modifications to the appliance, or departure from the manufacturers guidance on intended use, or, installation

contrary to the manufacturers recommendations may constitute a hazard.

Note

To ignore the **warning** and **caution** notices, and to ignore the advice from the manufacturer on installation, commissioning, servicing, or use, will jeopardise any applicable warranty, moreover, such a situation could also compromise the safe and efficient running of the appliance itself, and thereby constitute a hazard.

This appliance must be installed by a competent person and in accordance with European, National, and Local criteria, including any relevant standards, codes of practice the requirements of the current building Regulations (and in particular parts J & L), Health and safety regulations IEE regulations and any requirements of the local Authority, Fire Officer or insurers. Relevant standards may include BS6230, BS6891 and BS5588 parts 2 and 3.

Prior to installation the following points should be considered;

- a) The position of the heater for the optimum efficient distribution and circulation of warm air
- b) The position of the heater relative to the route of the flue
- c) The position of the heater relative to the supply of gas
- d) The position of the heater relative to the electrical services, wiring routes, and if appropriate, any additional controls.
- e) The position of the heater relative to the supply of fresh air
- f) The position of the heater relative to potential stratification / circulation problems, which generally occur at higher levels and which may be overcome through the provision of a suitable de-stratification unit.
- g) The position of the heater relative to service and maintenance requirements

Caution

The heater **must not** be installed within an area where the conditions are unsuitable, e.g. where the atmosphere is highly corrosive, has a high degree of salinity, or where high wind velocities may affect burner operation. Suitable protection should be provided for the appliance when it is located in a position where it may be susceptible to external mechanical damage from; for example, fork lift trucks, overhead cranes etc.

1.4 Delivery and pre-installation checks

The heater is supplied wrapped in heavy duty protective polythene, mounted on a pallet.

On receipt of the heater, the following checks should be carried out;

- a) The model is as per order
- b) That it is undamaged
- c) That it is suitable for the gas supply and pressure
- d) That it is suitable for the electrical supply

If any of these points are not satisfied then contact should be made with the Sales Office at Benson Heating as soon as possible by telephoning 01547-528534. In the case of claims for damage, this must be reported in writing within 24 hours of delivery, in order to comply with insurance criteria

1.5 Warranty

The heater is supplied with a 1 year parts and labour warranty and a further year on all parts excluding consumable's.

In addition to this there is also a 10 year time related warranty on the combustion chamber.

The warranty commences from the date of dispatch from the manufacturer, and is subject to the terms detailed within the Benson Heating 'conditions of business'.

Note (i)

The warranty may be invalidated if -

- a) The warranty registration/commissioning card has not been completed and returned to Benson Heating
- b) The installation is not in accordance with the general requirements of this manual
- c) The flue arrangement and air supply for the heater are not in accordance with the manufacturers recommendations, codes of practice, or similar standards
- d) Air flow through the heater is not in accordance with the manufacturers technical specifications
- e) Internal wiring on the heater has been tampered with or unauthorised service repairs undertaken
- f) The main electrical supply input to the heater has been interrupted during the heating mode
- g) The heater has been subject to and affected by the ingress of water in any form
- h) The heater is not operated at the rating(s) laid down in the manufacturers technical specifications
- i) The heater has not been operated or used within the normal scope of its intended application
- j) The manufacturer's recommended minimum service requirements have not been complied with

Note (ii)

All warranty claims must contain the following information to enable processing to take place;

- (1) Heater model
- (2) Heater serial number
- (3) Order reference/date of order, together with full installation details (name and address)
- (4) Details or symptoms of fault
- (5) Installers name and address.

Faulty parts must be returned to the Benson Heating Spares Department, the address of which is provided on the cover of this

manual. Any such parts will undergo inspection to verify the claim. Replacement parts supplied prior to this may be charged, and a credit supplied upon subsequent validation of the warranty claim. Consumable items are specifically not included within the scope of the warranty.

Note (iii)

Notification is required immediately a fault is suspected.

The manufacturer will not accept responsibility for any additional damage that has been caused, expense incurred, or consequential loss resulting from any failure of the heater(s).

SPECIAL RISK AREAS

Where it is proposed to install a heater within a special risk area (e.g. an area containing flammable vapours where petrol engined vehicles are stored parked or serviced where paint spraying occurs, or where woodworking machinery or other flammable dust creating process's are employed then restrictions, additional regulations concerning the heater flue wiring or controls may apply.

It is strongly recommended that you contact Benson Technical before installation

Caution

When used in room sealed mode it may be possible to install Variante heaters in areas containing flammable vapours, high levels of airborne dust combustible dust chlorinated or halogenated hydrocarbons degreasing solvents styrenes other laminating materials or airborne silicones. Benson Technical should be contacted before installation . Failure to do so may invalidate or reduce guarantee cover.

2.0 Installation

The location chosen for the heater must allow for the fitting of an effective flue system.

The location must also allow for adequate clearance for the air supply, return air circulation, gas supply, electrical supply, whilst also providing good and safe working access.

The heater must be installed so that it is level, supports for the heater must be sufficiently robust to withstand the weight of

the heater and any ancillary equipment Any combustible material adjacent to the heater or flue system must be so placed or shielded so that its surface temperature does not exceed 65°C. Generally a free blowing heater should be located at a height (measured from floor level to the base of unit) as detailed within section 2.1

Model VRA/C	250	330	410	490
Min	2.4	2.4	2.4	2.4
Max	5.0	5.0	5.0	5.0

Clearances VRABD in mm

Model	250	330	410	490
Above	300	300	300	300
Below	300	300	300	300
Right side	250	250	250	250
Left side	950	950	950	950

Left hand side = burner compartment side

VRABD free blowing heaters are at their most effective when located as close to the working area as possible. However care should be exercised to avoid directing the discharged air directly onto the occupants of the area to be heated.

Where the passage of cold air causes problems (e.g. by entrances, loading bays etc) it is considered favourable if the heater is positioned so as the discharge towards or across the cold air source from a distance from 1.5m - 6m dependent upon the size of the entrance and the air throw characteristics of the heater. On exposed walls heaters should be positioned so as to discharge towards, or along the length of the exposed wall.

In areas where it is proposed that more than one heater is to be installed, a general scheme of circulation should be drawn up and maintained, thereby offering the best heat distribution. Air pressure within the area heated and the outside air pressure must remain the same, factors influencing this would be the presence of extraction systems,

ventilation systems, and various types of process plant.
Applications should be suspended centrally over the area into which the warm air is to be discharged .

2.1 Installation Mounting Heights and Clearances

The Heater must be installed within the mounting heights indicated below
The following heights in metres
On a level non-combustible surface capable of adequately supporting the weight of the unit and ancillary equipment .

2.2 Heater Mounting

The heater and flue must be adequately supported by one of the following methods ;

- a) Suspension by steel drop rods or straps from the **M10** fixing points located on top of the heater
These must be of sufficient strength to safely carry the weight of the unit and ancillary equipment. The straps may only drop vertically to eyebolts, if used; **I.E.** They must not be joined to the eyebolt at an angle to the vertical, and eyebolts if used should be of an approved type.

2.3 Warm Air Circulation

The air heater should be positioned to enable maximum circulation of discharged warm air within the area to be heated, whilst taking account of personnel within the area, sources of cold air ingress , and obstructions.

Ensure louvres are adjusted outwards and ensure blades are not resonating

The air temperature rise on passing the heat exchanger is typically around 34⁰ C

A full and unobstructed return air path to the air heater must be provided (see 2.4 Air Supply).

Where the heater is positioned to deliver blown air through an opening in a wall, return air intakes should be located so that they cannot become blocked. Similarly these intakes must be positioned so as not to draw in odours, fumes, hazardous vapours or particles.

2.4 Air Supply for Combustion and Ventilation

Consideration must be given to the provision of air for the purposes of combustion and ventilation of the

heated space, requirements

MODEL	Minimum Free Area Of Ventilation Opening	
	High Level	Low Level
	cm ²	cm ²
250	None	158
330	None	211
410	None	263
490	None	315

plant room or enclosure where the heaters are to be installed .

It is strongly recommended that BS 6230 : 2005 is referred to for further information concerning ventilation

2.4.1 Heaters installed within the heated space

Where heaters are installed within the heated space (i.e. not a plant room , or enclosure) then

Combustion air or heater related ventilation air **will not be** required if -

- The heaters are installed in room sealed mode (ie with a positive connection to atmosphere of both flue and combustion air)

OR

- If the design air change rate of the heated space is 0.5 air changes per hour or greater

The design air change rate may be satisfied by natural infiltration or by mechanical ventilation.

Combustion air ventilation **will be** required if

- The heater(s) are installed with flue only (ie without the positive connection to atmosphere of a combustion air duct)

And

- The design air change rate of the heated space is less than 0.5 air changes per hour

Where heater(s) are installed without the positive connection of combustion ductwork within a heated space where air change rate of that heated space is less than 0.5 air changes per hour then it will be necessary to provide either natural ventilation openings to the heated space (Section 2.4.1.1 refers) or the mechanical ventilation of the heated space (Section 2.4.1.2 refers)

2.4.1.1 Natural Ventilation Openings to the Heated Space

If the heater(s) are to be installed without the positive connection of combustion air ductwork within a heated space, and where

the design air change rate of that heated space is less than 0.5 air changes per hour, then provision for low level natural ventilation openings only will be necessary. The minimum free area of the low level natural ventilation opening shall be

- 2 cm² for each kW of rated heat input

MODEL	Minimum Free Area Of Ventilation Opening	
	High Level	Low Level
	cm ²	cm ²
250	394	394
330	527	527
410	656	656
490	787	787

The low level natural ventilation opening should be situated on an external wall and be within 1000 mm of floor level for natural gas and ideally at floor level for lpg gas installations but in any event no higher than 250 mm.

The table below provides specific data for each heater model as -

2.4.1.2 Mechanical Ventilation to the Heated Space

In the event that the heater(s) are to be installed without the positive connection of combustion ductwork within a heated space and where that heated space has a design air change of less than 0.5 air changes per hour and that the installer prefers to mechanically ventilate the heated space rather than provide ventilation openings then -

- The heated space needs to be mechanically ventilated so that the design air change is 0.5 air changes

MODEL	Minimum Free Area Of Ventilation Opening	
	High Level	Low Level
	cm ²	cm ²
250	158	316
330	211	422
410	263	525
490	315	630

per hour or greater.

- It is a requirement that the mechanical ventilation shall be of the input! Type with either natural or mechanical extraction
- Systems of mechanical extraction with a natural inlet shall not be used
- It is necessary to provide an automatic means to safely inhibit heater(s) operation should mechanical air supply fail for any reason

2.4.2 Heaters Installed within a Plant Room or Enclosure

A plant room means a room housing the heater plant and probably other items of building service plant and would generally have generous space for maintenance

An enclosure is where the heater is installed within a compartment or confined area where space is limited

Where heaters are installed within a plant room or enclosure then provision for both combustion air and / or air for general ventilation will be required by means of high

and low level ventilation openings (sections 2.4.2.1 and 2.4.2.2 refer to plant room applications and sections 2.4.2.3 and 2.4.2.4 refer to enclosure applications).

The low level natural ventilation opening should be situated on an external wall and be

MODEL	Minimum Free Area Of Ventilation Opening	
	High Level	Low Level
	cm ²	cm ²
250	394	394
330	527	527
410	656	656
490	787	787

MODEL	Minimum Free Area Of Ventilation Opening	
	High Level	Low Level
	cm ²	cm ²
250	394	788
330	527	1053
410	656	1312
490	787	1574

Alternatively the plant room or enclosure may be mechanically ventilated (section 2.4.2.5 refers)

within 1000 mm of floor level for natural gas and ideally at floor level for l.p.g gas installations but in any event no higher than 250 mm.

2.4.2.1 Natural Ventilation Openings to Plant Rooms for Room Sealed Heaters

For plant room applications the minimum free area of ventilation opening will depend upon whether the heater(s) is installed in room sealed mode (ie with a positive connection to atmosphere of both flue and combustion air) Or with flue only (ie without the positive connection to atmosphere of a combustion air duct)

Where the heater(s) is installed in a plant room and in room sealed mode (ie with a positive connection to atmosphere of both flue and combustion air) the minimum free area of ventilation opening needs to be

- At high level 5 cm² for each kW of rated heat input
- At low level 5 cm² for each kW of rated heat input

The high level ventilation opening should be sited on an external wall and positioned as high as is practical and always within the top 15% of the wall height

The table below provides specific data for each heater model as -

2.4.2.2 Natural Ventilation Openings to Plant Rooms for Flued Heaters

Where the heater(s) is installed in a plant room and in flue mode (ie without a positive connection to atmosphere of combustion air ductwork) the minimum free area of ventilation opening needs to be

- At high level 2 cm² for each kW of rated heat input
- At low level 4 cm² for each kW of rated heat input

The high level ventilation opening should be sited on an external wall and positioned as high as is practical and always within the top 15% of the wall height

The low level natural ventilation opening should be situated on an external wall and be within 1000 mm of floor level for natural gas and ideally at floor level for l.p.g gas installations but in any event no higher than

250 mm.

The table below provides specific data for each heater model as -

2.4.2.3 Natural Ventilation Openings to

MODEL	Mechanical Ventilation Rate for Plant Room or Enclosure
	M ³ /h
250	327
330	436
410	543
490	652

Enclosures for Room Sealed Heaters

For enclosure applications the minimum free area of ventilation opening will also depend upon whether the heater(s) is installed in room sealed mode (ie with a positive connection to atmosphere of both flue and combustion air)

Or with flue only (ie without the positive connection to atmosphere of a combustion air duct)

Where the heater(s) is installed in a plant room and in room sealed mode (ie with a positive connection to atmosphere of both flue and combustion air) the minimum free area of ventilation opening needs to be

- At high level 5 cm² for each kW of rated heat input
- At low level 5 cm² for each kW of rated heat input

The high level ventilation opening should be sited on an external wall and positioned as high as is practical and always within the top 15% of the wall height

The low level natural ventilation opening should be situated on an external wall and be within 1000 mm of floor level for natural gas and ideally at floor level for l.p.g gas installations but in any event no higher than 250 mm.

The table below provides specific data for each heater model as -

2.4.2.4 Natural Ventilation Openings to Enclosures for Flued Heaters

Where the heater(s) is in an enclosure and in flue only mode (ie without a positive connection to atmosphere of combustion air ductwork) the minimum free area of ventilation opening needs to be

- At high level 5 cm² for each kW of rated heat input
- At low level 10 cm² for each kW of rated heat input

The high level ventilation opening should be sited on an external wall and positioned as high as is practical and always within the top 15% of the wall height

The low level natural ventilation opening should be situated on an external wall and be within 1000 mm of floor level for natural gas and ideally at floor level for l.p.g gas installations but in any event no higher than 250 mm.

The table below provides specific data for each heater model as -

2.4.2.5 Mechanical Ventilation to a Plant Room or Enclosure

In the event that the installer prefers to mechanically ventilate the plant room or enclosure rather than provide ventilation openings then -

- The plant room or enclosure needs to be mechanically ventilated at the rate of 4.14 m³/h of fresh air per kW or rated heat input.
- It is a requirement that the mechanical

Provision for the disconnection of the flue for servicing and inspection purposes must also be made.

The position of the flue and its terminal should be such that it does not impair the combustion process. It should terminate in an exposed position so as to allow the free escape of flue gases without risk of their re-entering the building through windows, ventilation ports etc.

The following distances in mm's should be observed

200 below guttering or eaves

300 from corners or openings (windows doors etc) and from other horizontal terminals on same wall

1200 from a facing surface

1500 from another terminal vertically on the same wall

2000 from ground level

The heaters must be connected to the flue system supplied by Benson Heating and be capable of withstanding the stresses and loadings associated with normal use. When designing the flue system the prevention of the formation and entrapment of condensation must be a key consideration. Horizontal flue should be fitted ensuring a slight gradient approx 2° towards the terminal

Where condensation is unavoidable traps should be included to encourage the condensates to flow freely to a point from which they may be released, preferably into a gully.

The condensate pipe from the flue to the disposal point must be made from corrosion resistant pipe of not less than 25mm internal diameter.

If the flue passes through a wall, ceiling, or roof made from combustible material then it has to be sleeved so as to provide a minimum of a 25mm void between the exterior of the flue and the internal wall of the sleeve.

C₃₂ Vertical Co axial flue Kit options

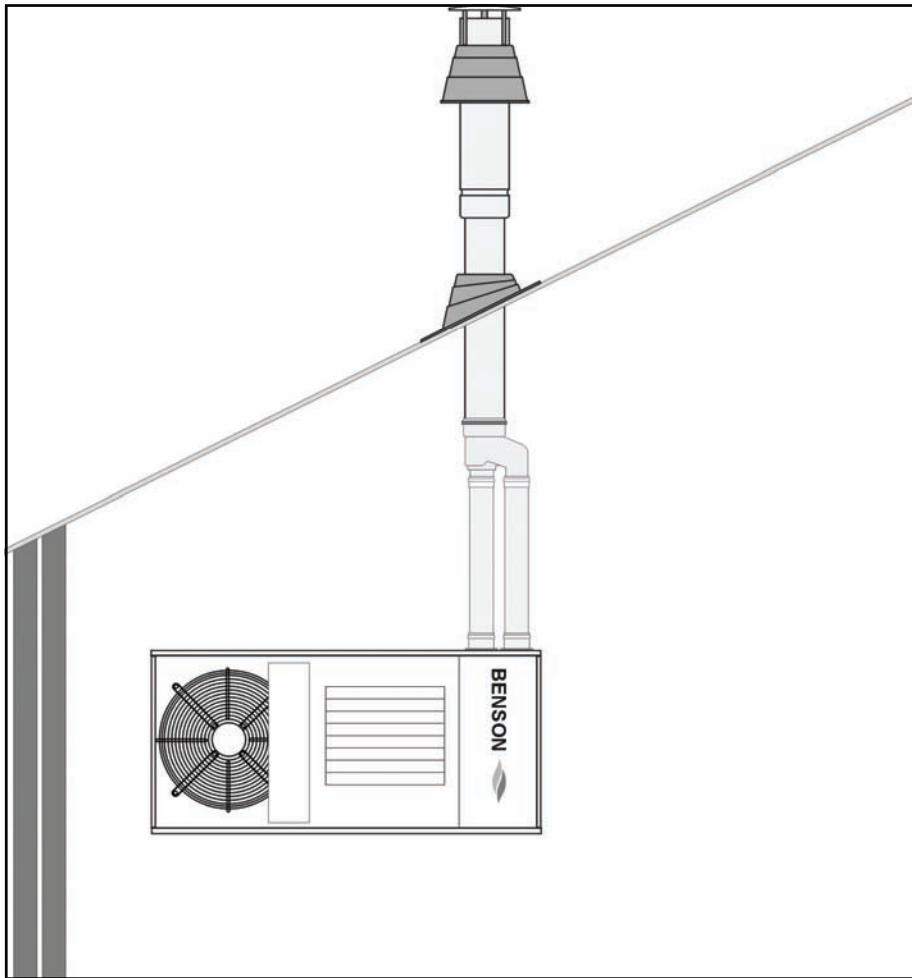

L1 maximum combined flue length 10 metres

Coaxial Terminal

Part No
33-55-207

Extra pipes to extend the flue are available as an option

Pipe Ø 130 x 1000 mm	33-54-201
Pipe Ø 130 x 500 mm	33-54-202
Pipe Ø 130 x 250 mm	33-54-203
Bend Ø 130 x 45 ⁰	33-54-204
Bend Ø 130 x 90 ⁰	33-54-205

Option C₁₂ Not Illustrated Contact Benson Technical Dept

In this configuration the heater is connected to a horizontal flue system discharging the products of combustion and bringing in the combustion air from outside the building in which the heater is located.

The outlet / inlet must be through the wall and may be made with two separate pipes or with a horizontal coaxial concentric terminal.

Not always practical in the Bi Directional configuration.

Option B₂₂

In this configuration the heater is connected to a single flue pipe to discharge the products of combustion outside the building either through the roof or through a wall. The air for combustion is taken from inside the building.

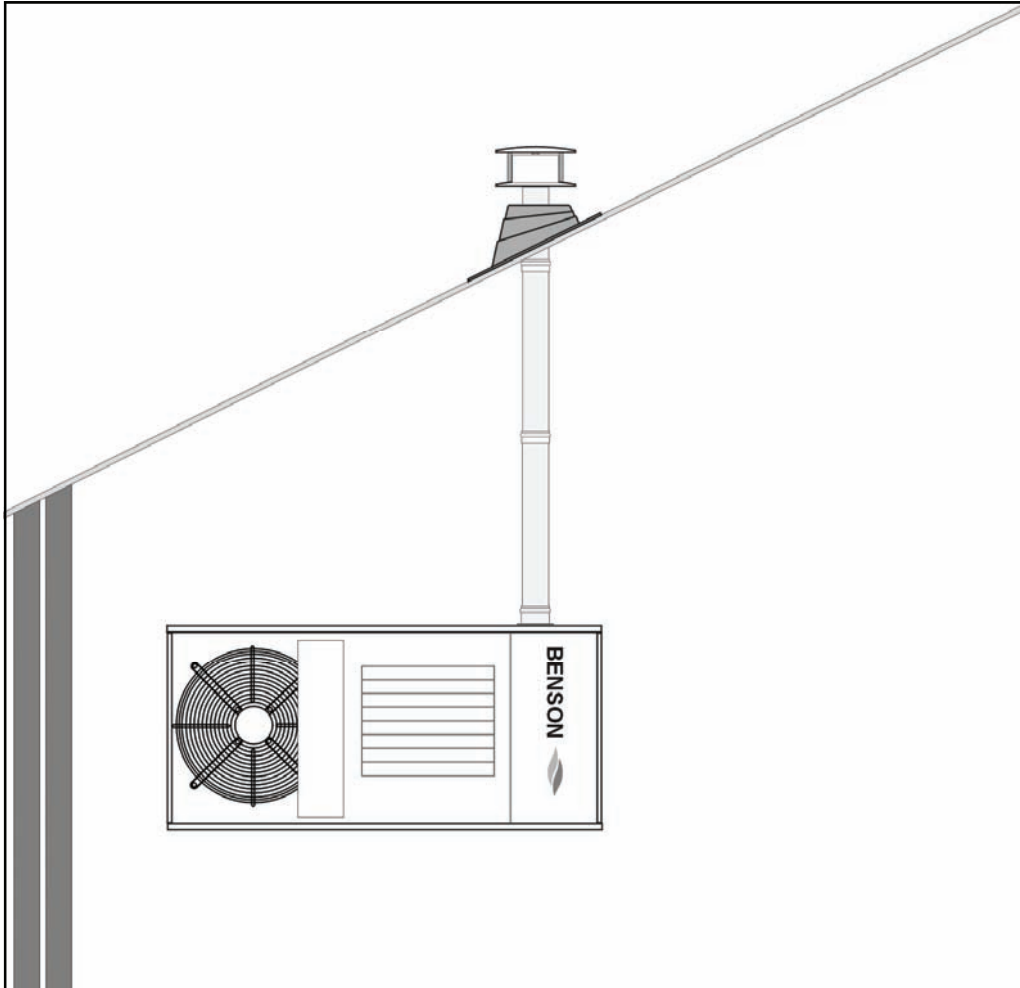

L1 maximum flue length 10 metres

Universal Terminal	Part No
Extra pipes to extend the flue are available as an option	33-54-207
Pipe Ø 130 x 1000 mm	33-54-201
Pipe Ø 130 x 500 mm	33-54-202
Pipe Ø 130 x 250 mm	33-54-203
Bend Ø 130 x 45 ⁰	33-54-204
Bend Ø 130 x 90 ⁰	33-54-205

Heater	Unit	Flue Exit		Flue Exit	
		MIN.	MAX.	MIN.	MAX.
250	m	1,00	8,00	1,00	10,00
330	m	1,00	8,00	1,00	10,00
410	m	1,00	8,00	1,00	10,00
490	m	1,00	8,00	1,00	10,00

Caution

It is imperative that the flue should be properly sealed where it passes through the roof, this can best be achieved by using the approved method of roof flashing plate and cravat. The flue spigot outlet on all Variante heaters is in horizontal configuration.

Note

It should be noted that claims made under warranty and attributed to the ingress of water may not be considered especially if an approved method of sealing has not been used, or if the design of the flue has not made provision for possible condensation problems.

It is also recommended that BS5854: 1980 and BS5440: parts 1 and 2 are used as a consultative document when considering flue requirements.

If terminating through a wall only use Benson approved horizontal terminals

2.6 Electrical Installation

All electrical wiring and connections must be in accordance with the relevant European, National, and Local regulations as well as to IEE

Standards.

Ensure that the Electric and Gas supplies are turned off before any electrical work is carried out on the heater.

Also ensure that wiring cannot make contact with any metal surfaces liable to be subject to high temperatures, and where insulation of the wiring could be impaired as a result of such contact.

All Variante models must be earthed.

Warning

Ensure that the electrical supply is compatible to the heater.

**ALL HEATERS
ARE
NEUTRALLY
RESET**

Caution

The main electrical supply must not be switched off or disconnected as a method for stopping the heater, the exception to this is in the event of an emergency, or when the heater has been allowed to cool sufficiently to prevent any damage from being sustained to the heater or its controls (ie: during servicing).

Claims for damage will not be considered if they have resulted from incorrect wiring or the incorrect use of the heater

Each heater requires a permanent 230V 50Hz 1ph electrical supply, which must be wired through a fused isolator fitted with a fuse of the correct rating (see section 7.1). The correct supply connection points for the live, neutral, and earth.

Wiring diagrams are also detailed within this manual, (section 6.0)

The electrical supply isolator should be mounted adjacent to the air heater in an easily accessible position to allow for servicing isolation, or emergency shut off.

Electrical panel

Warning

Ensure that the mains isolator is turned **OFF** before undertaking any electrical work on the heater. Access to the electrical panel is gained by opening the right hand heater side panel.

Warning

Ensure that all connections are secure and that there are no loose strands which could bridge across the terminals.

A minimum conductor size of 1.0 mm (diameter) is required.

Caution
When using CP4 Optimised Controller Consideration should be made when routing the cable between the control and heater. Avoiding where possible any existing cables and

switch gear as any induced voltage may affect the operation of the sequential control box within the heater.

It is recommended that screened cable is used when the control is to be sited more than 10 metres away from the

heater

One electrical panel per heater is required, unless heaters are specified for multiple heater control applications. On no account should more than one heater be connected to a single time switch or thermostat.

The only

exception to this is when a control panel suitable for multiple heater applications is supplied by the manufacturer.

Any ancillary electrical items e.g. room thermostats , time switches, remote panels etc, must be wired into the heater electrical circuit in accordance with the diagrams provided

Note

When external controls operate to switch the heater **OFF**, power to the heater should remain to allow the fan to continue to operate to sufficiently cool the heater thereby preventing damage to the heat exchanger.

Fan limit control

(Situated inside the right hand side panel)

FAN ON 50° **FAN OFF 30°**

These settings may require slight adjustment on commissioning

Fan control (white button)

The fan control switch features normally open 230V contacts, and is wired to control the live supply to the fan motor . When the circuit is made, the fan will switch on when the heat anticipator has closed the fan switch contacts.

When the thermostat or time switch shuts down the burner, the fan will continue to run until the thermal switch has cooled sufficiently to prevent the residual heat from damaging the heater or its controls.

On start up the fan delay prevents air being circulated until the desired temperature is achieved

Limit control (red button) SET at 100°

An adjustable high temperature manual reset limit control. If this control needs resetting the cause should be determined and rectified immediately.

On models with two fans a second limit control is situated inside the right side panel and is wired in series. Operation of either switch will shut down the heater. On larger models there will be additional limit stats fitted

Caution

The power supply to the fan must not be interrupted, the only time when power supply can be disconnected or interrupted is during servicing or in emergencies

If there is a requirement for the heater to be switched off over night then the gas valve circuit should be opened via a time switch, etc, as per the wiring instructions and diagrams supplied within section 6.0 of this manual.

2.7 Gas installation

Warning

Please read notice on page 3 of this manual

As there have been recorded instances of the deposition of copper sulphide dust within the valves and orifices of gas appliances as a direct result of a reaction between the hydrogen sulphide contained in some natural gasses and copper pipe we recommend that the heater(s) should not be connected to any natural gas pipe distribution system which utilizes copper pipework, including final connections. Instead steel pipework should be used throughout.

In the event that it is impractical to use steel pipework or where installers are obliged or insist on using elements of copper pipework within the installation then we strongly recommend that the gas supplier be consulted as specific conditions and requirements may be necessary.

The Variante range of heaters are all manufactured and pre set for use with Natural Gas, or Lpg and all feature a 3/4" BSP connection point. Prior to installation the supply characteristics (gas type and pressure) must be checked to ensure that they are in accordance with the data plate on the heater.

The gas supplier should check that the meter and service connection to the heater are capable of delivering the required volume of gas, thereby ensuring that the minimum burner pressure can be achieved.

Consideration should be given to the

pressure drop on single and multi heater installations and the effect they may have on other plant sharing the supply.

If it is necessary to fit a gas pressure booster, the controls must include a low pressure cut off switch which must be fitted on the supply / inlet side of the booster. It is also a requirement that the gas supplier is advised prior to the installation or fitting of the booster.

Each heater supply must be fitted with a separate isolating cock positioned adjacent to and upstream of the union which must be sited outside the heater.

The isolating cock should be of the 90° turn type and should be clearly marked **OPEN / CLOSED** it should also be installed so as to fall to the closed position

An approved gas jointing compound must be used on all joints and unions and the system purged and tested for soundness prior to final connection

The connection to the heater can be made by way of either an approved flexible coupling or rigid connection . Threaded connections must comply to ISO 288/1 or ISO 7/1 further information concerning accepted European practice is detailed in BS EN1020 1998.

The diameter of the pipework from the isolating cock to the burner must not be less

than the diameter of the connection into the multiblock.

Note

Reference to The Institute of Gas Engineers publications Utilisation Procedures IGE/UP1 and IGE/UP2 together with reference to BS6891 is strongly advised.

3.0 Commissioning

Note

It is a requirement that only suitably qualified and competent personnel are allowed to undertake the commissioning of the heater.

It is also strongly recommended that prior to commissioning the engineers familiarises themselves with the heater. the specific requirements of the installation / application, and the information contained within the manual.

Warning

All heaters are subject to a rigorous test programme prior to despatch, whilst such a programme does involve pre-commissioning and the setting of the heater to operate efficiently and within its designed operational limits this does not mean that the function of thorough on site commissioning is less important

It is strongly recommended that the equipment used for the sampling and analysis of the flue gases is accurate to within +/- 0.1% and maintained so that it is regularly calibrated.

The following pre-commissioning checks should be undertaken, having first

ensured that the gas and electrical supplies are turned off.

- (a) Check that all panels and fasteners are secure and in place.
- (b) Check that the heater is mounted safely.
- (c) Check that the flue is sealed, secured, and adequately supported.
- (d) Check that the fan is free to rotate, that the fan is secured to its shaft, and that the guards and fan assembly are all in place and properly secured.
- (e) Check that the heater is installed so that it is not tilted and remains square.
- (f) Check that the outlet louvres (Axial heaters) are set to offer minimum resistance to air flow.

3.1 Electrical pre-tests

The electrical safety checks must include the following

- a) Test for earth continuity
- b) Test for resistance to earth
- c) Check live and neutral connections are correct.
- d) Check to ensure that when the external controls operate to switch the heater off, power remains to the fan

3.2 Gas supply pre-test

Ensure that the service pipework has been installed purged and tested in accordance

Fault Finding

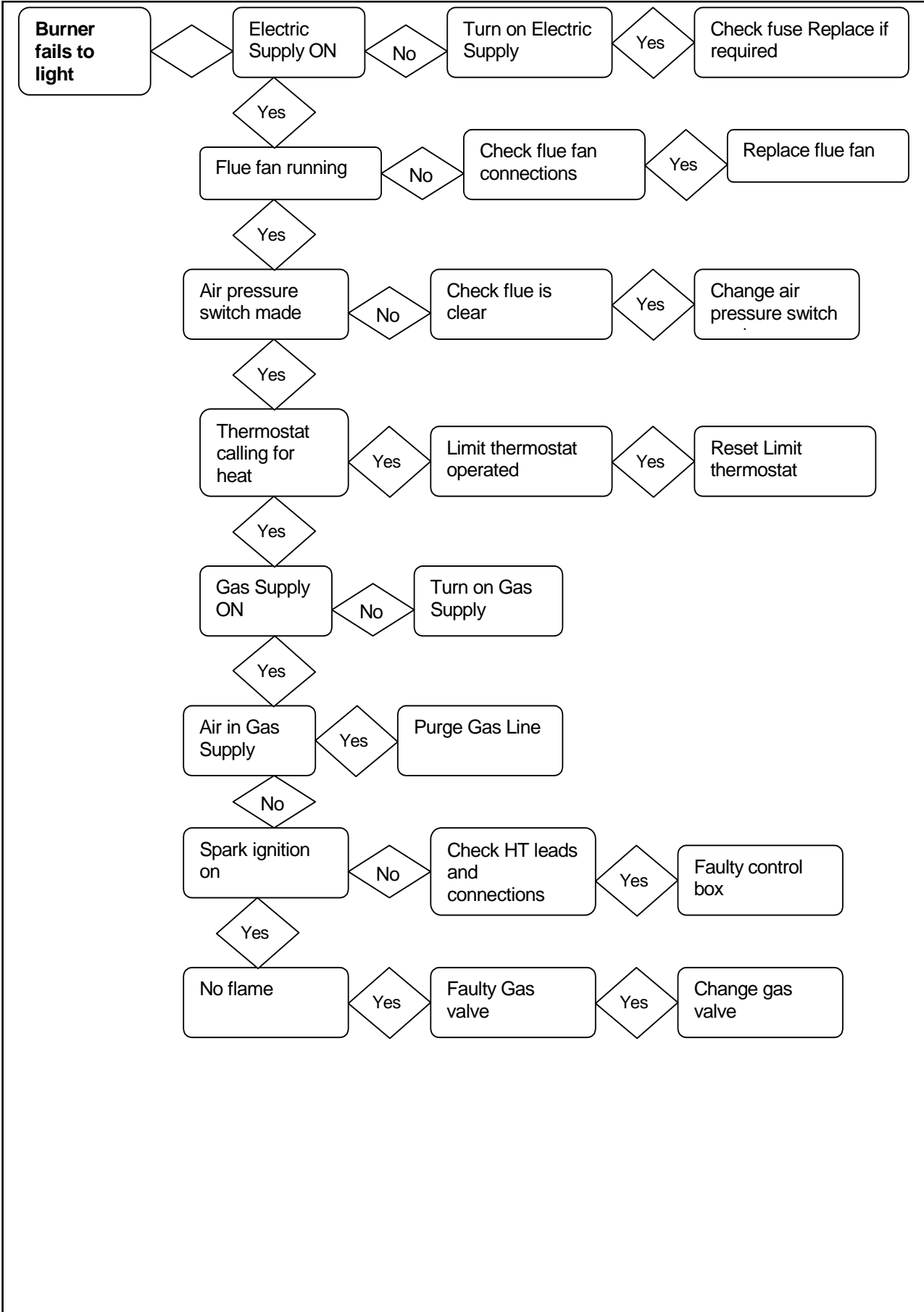

Fault finding cont'd

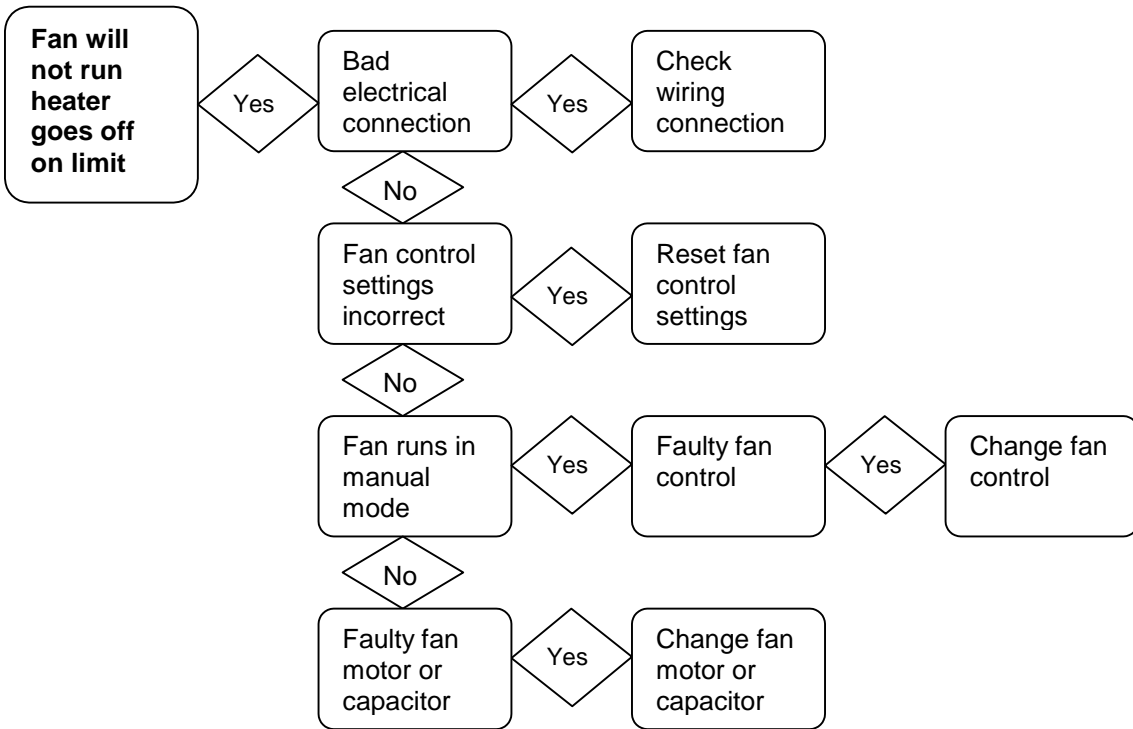

Wiring Diagrams VR 250-330 Auto Ignition

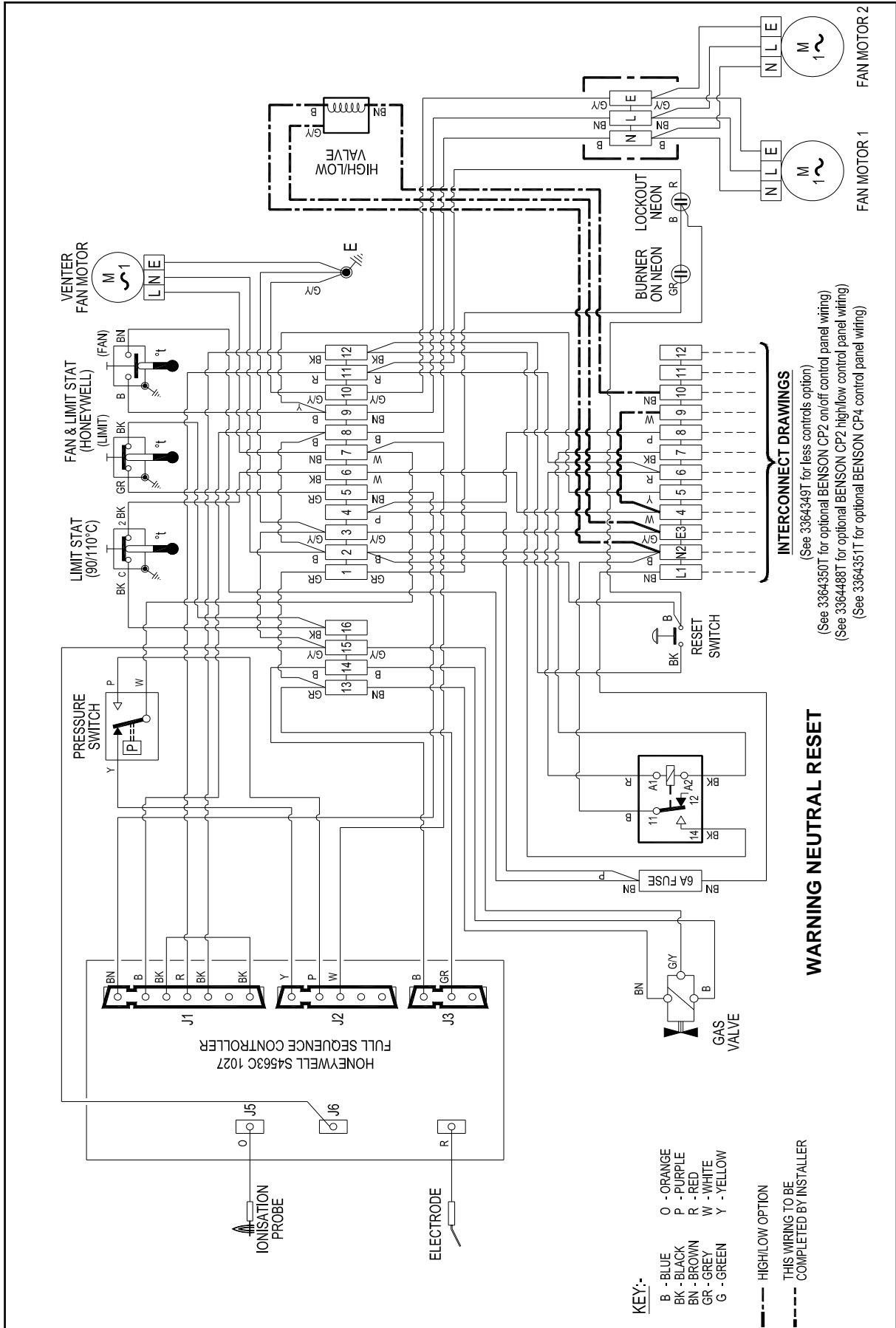

Wiring Diagram VRBD 410- Auto Ignition

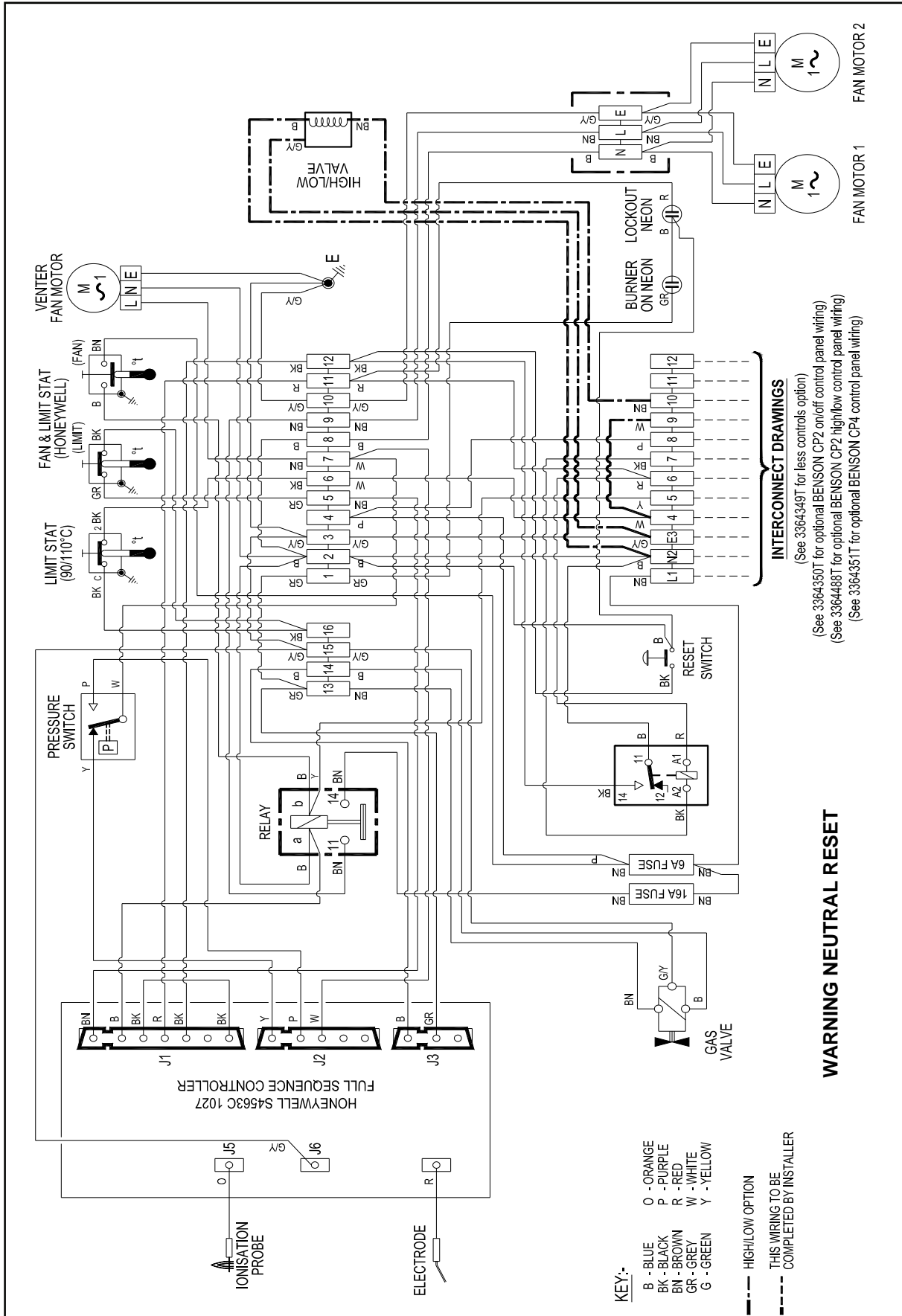

Wiring Diagram VRBD 490- Auto Ignition

TBA

Wiring Connection CP2 On/Off 33-64-350T

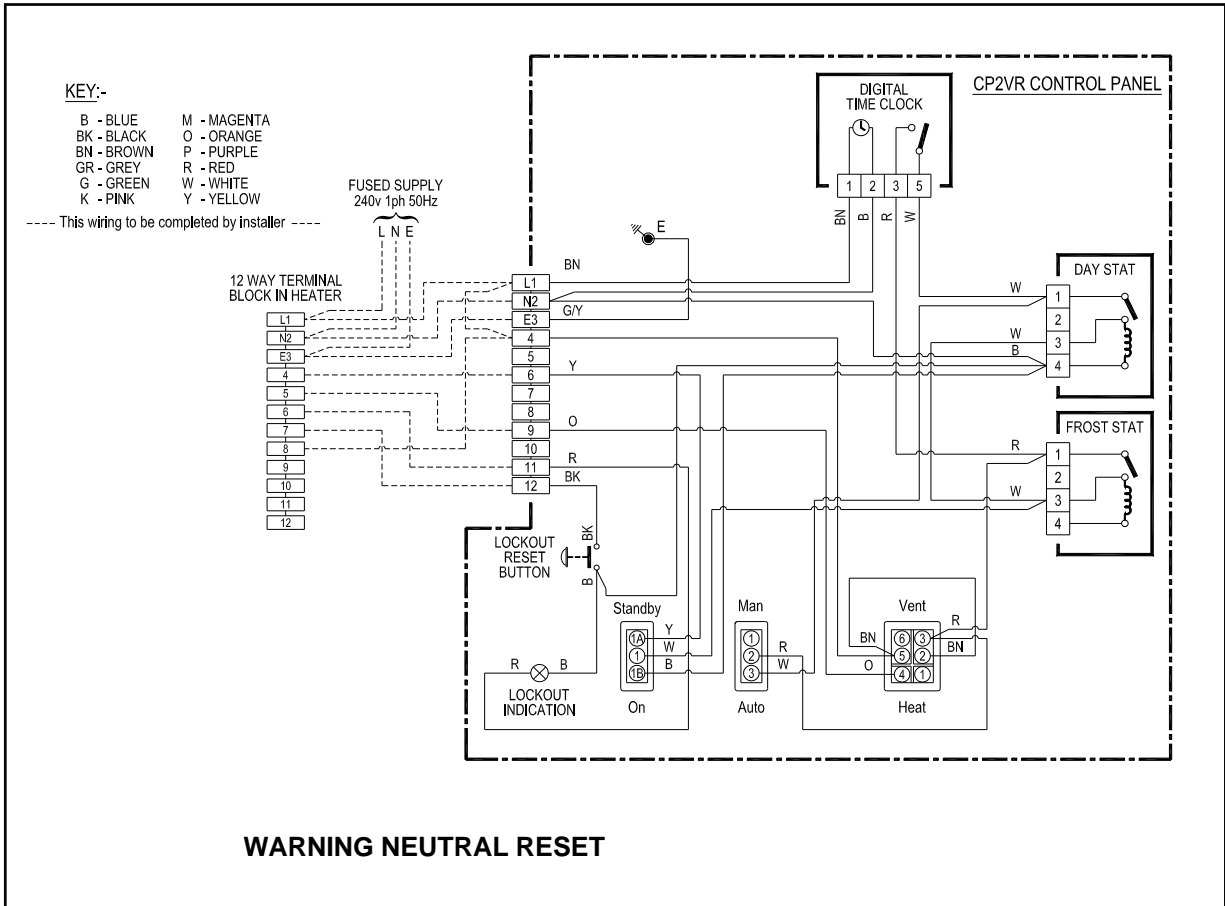

Wiring Connection CP2 Hi/Lo 33-64-488T

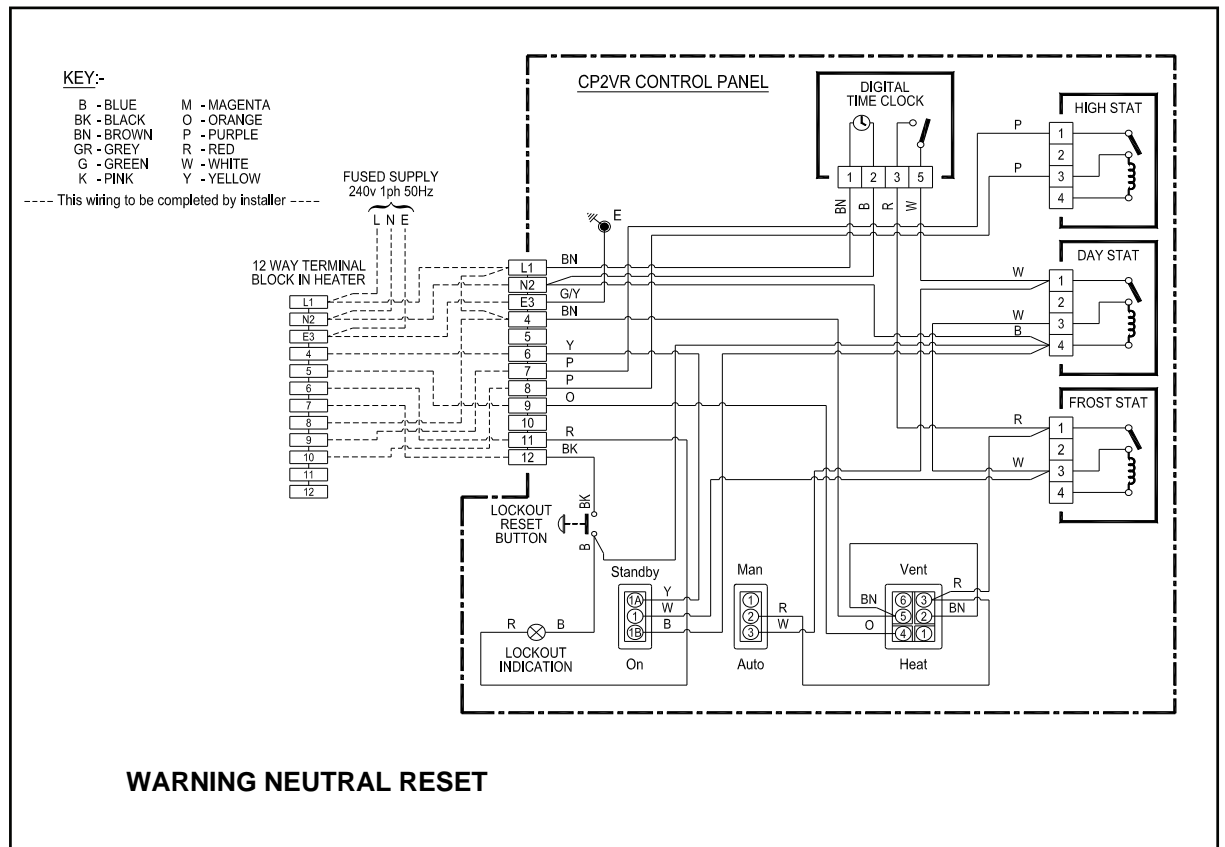

CP4 Controller Connections 33-64-351T

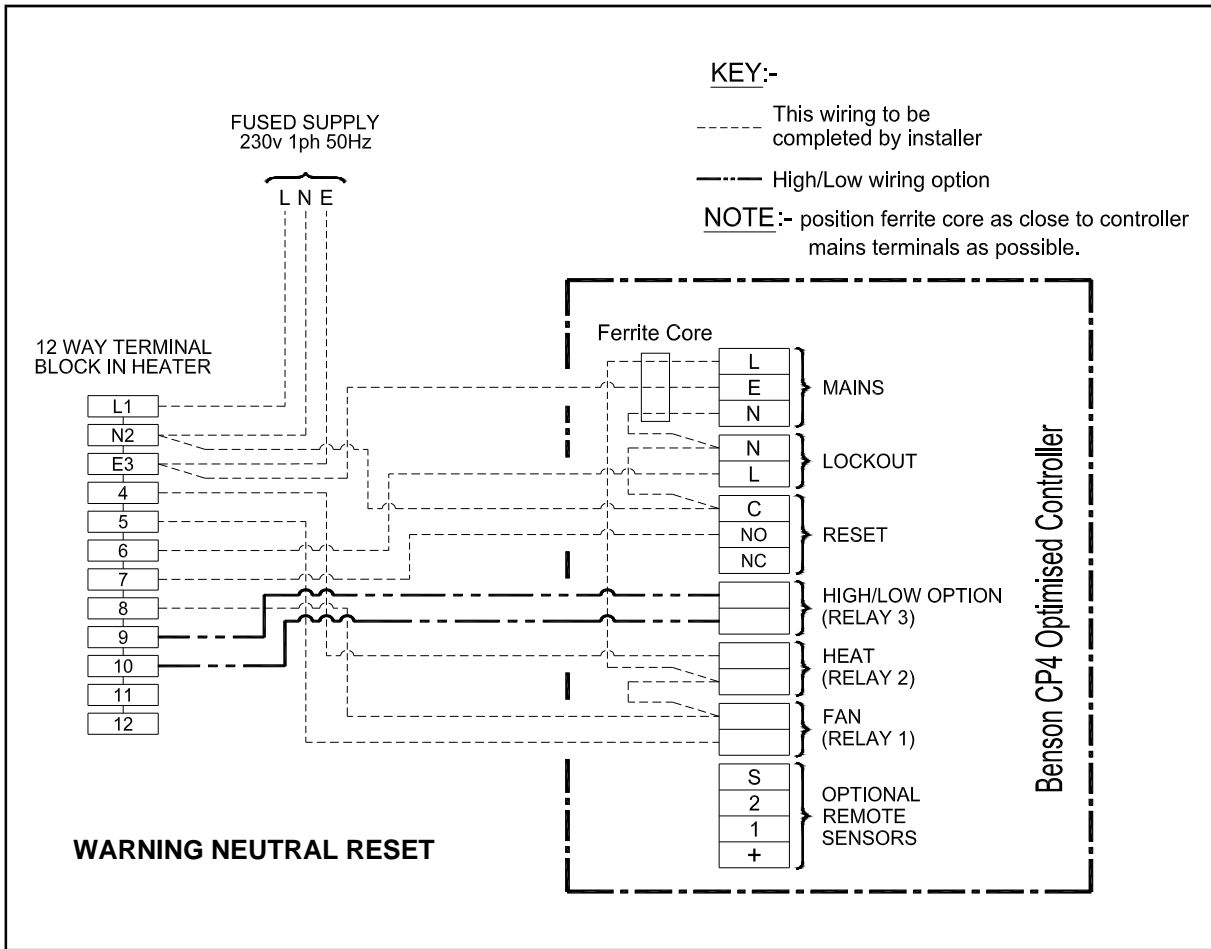

Less Controls Connections 33-64-349T

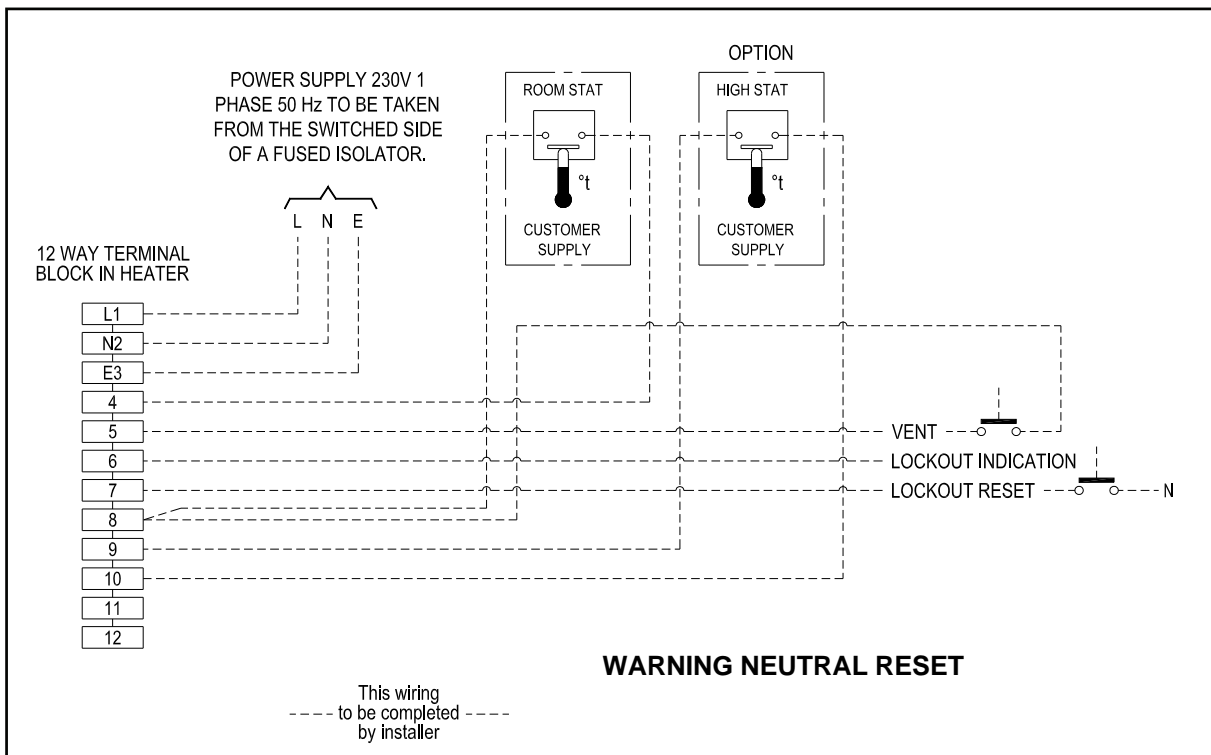

7.1 Technical Data Common Information

Appliance Type	B ₂₂ C ₃₂ C ₁₂
PIN / report no	0063BQ5461
Electrical Supply	230V 50Hz 1ph
Fuse Rating	6 AMP
IP Rating	IP20
Fan Limit Settings	Fan On 50°C Fan Off 30°C Limit 100°C

Country	Approved Gas Category
AT,CH,CZ,DK,EE,ES,FI,GB,GR,HU,IE,IT IS,LT,LV,NO,PT,RO,SE,SI,SK,TR	I _{2H}
BE,CZ,NL,FR,DE,IE,IT,ES,CH,PT,GB,SE, SK,SL,PT,PL,TR	I _{3P}
PL,LU,DE,RO	I _{2E}
PL	I _{2LS}
PL	I _{2LW}

Natural Gas (G20 I_{2H}) Tubular Heater

The minimum allowable pre-purge time requires calculating [BS EN1020:1998 clause 6.38]. To do this only the Carbon Dioxide CO₂ figure needs to be measured.

E.G. on a model 250 the calculated minimum time is = $286.2 / ((100 / \text{CO}_2) + 1)$

If the measured CO₂ is 6.7%

Then $100 / 6.7 = 14.9$

$14.9 + 1 = 15.9$

Therefore minimum pre-purge time is = $286.2 / 15.9 = \mathbf{18.0 \text{ seconds}}$

The calculation to be conducted is given below for all models:

Model 250 Minimum pre-purge time = $286.2 / ((100 / \text{CO}_2) + 1)$

Model 330 Minimum pre-purge time = $269.7 / ((100 / \text{CO}_2) + 1)$

Model 410 Minimum pre-purge time = $261.4 / ((100 / \text{CO}_2) + 1)$

Model 490 Minimum pre-purge time = $269.2 / ((100 / \text{CO}_2) + 1)$

The pre-purge time must then be measured. If the measured pre-purge time is lower than the calculated time STOP and contact Benson Heating.

Propane (G31 I_{3P}) Tubular Heater

The minimum allowable pre-purge time requires calculating [BS EN1020:1998 clause 6.38]. To do this only the Carbon Dioxide CO₂ figure needs to be measured.

E.G. on a model 250 the calculated minimum time is = $724.7 / ((300 / \text{CO}_2) + 2.01)$

If the measured CO₂ is 8.0%

Then $300 / 8.0 = 37.5$

$37.5 + 2.01 = 39.51$

Therefore minimum pre-purge time is = $724.7 / 39.51 = \mathbf{18.3 \text{ seconds}}$

The calculation to be conducted is given below for all models:

Model 250 Minimum pre-purge time = $724.7 / ((300 / \text{CO}_2) + 2.01)$

Model 330 Minimum pre-purge time = $682.8 / ((300 / \text{CO}_2) + 2.01)$

Model 410 Minimum pre-purge time = $661.7 / ((300 / \text{CO}_2) + 2.01)$

Model 490 Minimum pre-purge time = $681.6 / ((300 / \text{CO}_2) + 2.01)$

The pre-purge time must then be measured. If the measured pre-purge time is lower than the calculated time STOP and contact Benson Heating.

7.2 Technical Data

NAT GAS / LPG	MODEL	250	330	410	490
HEAT OUTPUT	kW Btu	72.0 246,000	96.0 328,000	120.0 409,000	144.0 491,000
HEAT INPUT (Nett)	kW Btu	78.8 268,900	105.2 359,000	130.4 445,000	156.5 534,000
EFFICIENCY	% Nett	91.4	91.2	91.5	91.5
EFFICIENCY	% Gross	82.3	82.1	82.4	82.4
HEAT OUTPUT Low Fire	kW Btu	46.6 159,000	62.2 212,250	77.5 264,430	93.0 317,300
HEAT INPUT (Nett) Low Fire	kW Btu	50.7 173,000	67.6 230,720	83.8 286,000	100.6 343,200
GAS CONNECTION	BSP/Rc	3/4"	3/4"	3/4"	3/4"
MIN INLET PRESS NAT GAS	mbar Ins WG	17.5 7	17.5 7	17.5 7	17.5 7
BURNER PRESSURE NAT GAS	mbar Ins WG	8.7 3.5	8.7 3.5	9.2 3.7	9.2 3.7
BURNER PRESSURE NAT GAS Hi Lo	Hi mbar Lo mbar	8.7 3.5	8.7 3.5	9.2 3.8	9.2 3.8
MAIN INJECTOR NATURAL GAS	mm No Off	3.4 6	3.4 8	3.4 10	3.4 12
NAT GAS CONSUMPTION	ft ³ /hr m ³ /hr	294 8.33	393 11.12	490 13.87	587 16.63
MIN INLET PRESS LPG	Mbar Ins WG	37.0 14.8	37.0 14.8	37.0 14.8	37.0 14.8
BURNER PRESSURE LPG	Mbar Ins WG	25.5 10.2	25.5 10.2	25.5 10.2	25.5 10.2
LPG PROPANE CONSUMPTION	m ³ /hr Kg/h	3.21 5.94	4.28 7.92	5.34 9.88	6.41 11.86
MAIN INJECTOR PROPANE GAS	Mm No Off	2.0 6	2.0 8	2.0 10	2.0 12
TEMPERATURE RISE	°C °F	32 58	34 61	32 58	32 58
AIR FLOW	ft ³ /min m ³ /sec	4026 1.90	4789 2.26	6527 3.08	8010 3.78
VRABD THROW	ft mtrs	203 62	210 64	249 76	256 78
FAN STATIC PRESSURE	Pa Ins WG	150 0.60	180 0.72	200 0.80	200 0.80
SOUND LEVEL @ 3m	DbA	61	63	66	66
FLUE DIAMETER *	mm	130	130	130	130
COMBUSTION AIR DIA	mm	130	130	130	130
SUPPLY VOLTAGE	Axial	230/1/50	230/1/50	230/1/50	230/1/50
ELECTRICAL POWER(AMPERES)	Axial	2.8	4.2	4.8	5.8
INTERNAL FUSE RATING AMPERES	VRA	6	6	6	6
POWER ABSORPTION Kw	Axial	0.56	0.88	0.95	1.2
MOUNTING HEIGHT (MTRS)	Min Max	2.4 3.5	2.4 3.5	2.4 3.5	2.4 3.5
GROSS FLUE TEMP	°C	150	150	160	160
WEIGHT Kgs	Axial	181	203	242	279
AIR PRESS SWITCH	mbar	1.65	1.65	1.65	1.65
FLUE RESISTANCE	min mbar max mbar	-0.2 +0.4	-0.2 +0.4	-0.2 +0.4	-0.2 +0.4

8.0 Parts list

MODEL	250	330	410	490
Fan Plenum Axial	33-64-585	33-64-586	33-64-587	33-64-588
Fan Axial VRA Standard	28-09-062	28-09-092	28-09-056	28-09-098
Fan Limit Stat	28-60-021	28-60-021	28-60-021	28-60-021
Gas Valve	28-30-181	28-30-181	28-30-184	28-30-184
Control Box	29-01-183	29-01-183	29-01-183	29-01-183
Injector Natural Gas	33-64-145	33-64-145	33-64-145	33-64-145
Injector LPG Propane	33-64-147	33-64-147	33-64-147	33-64-147
Inshot	33-64-160	33-64-160	33-64-160	33-64-160
Gas Manifold	33-64-017	33-64-018	33-64-153	33-64-154
Air Pressure Switch	28-40-139	28-40-139	28-40-139	28-40-139
Flue Fan	28-09-089	28-09-089	28-09-090	28-09-090
Run Neon Green	28-50-038	28-50-038	28-50-038	28-50-038
Lockout Neon Red	28-50-030	28-50-030	28-50-030	28-50-030
Overheat Thermostat	28-60-039	28-60-039	28-60-039	28-60-039
Electrode	33-64-193	33-64-193	33-64-193	33-64-193
Ionisation Probe	33-64-194	33-64-194	33-64-194	33-64-194
Fuse Holder	28-07-050	28-07-050	28-07-050	28-07-050
Fuse	28-07-048	28-07-048	28-07-048	28-07-048
Reset Switch	28-40-141	28-40-141	28-40-141	28-40-141
Reset Relay 230 Volt	28-25-039	28-25-039	28-25-039	28-25-039
Optimised Control	B-CP4	B-CP4	B-CP4	B-CP4

V²RABD

MODEL	A	B	C	D	E
250	650	256	267	95	175
330	800	256	267	95	167
410	980	256	267	95	175
490	1150	259	272	95	177

DIMENSIONS IN mm

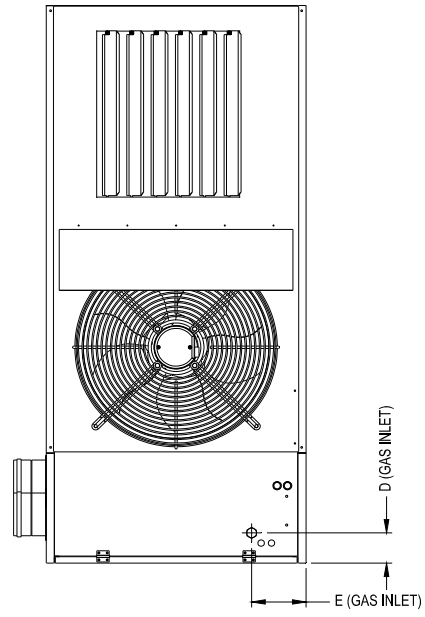
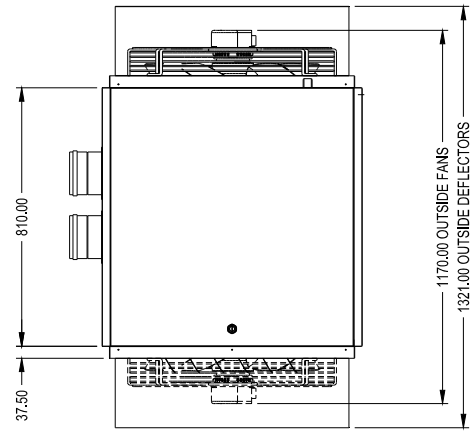
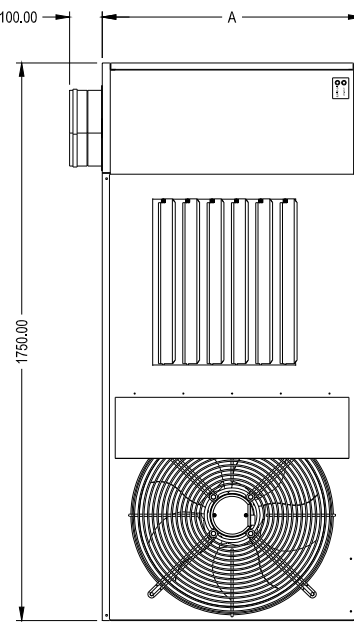
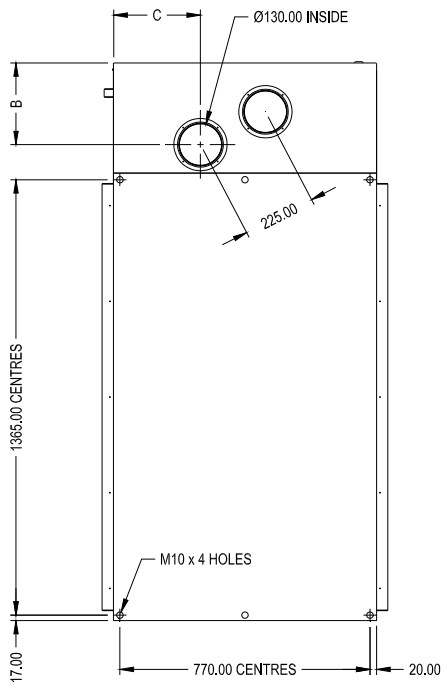

Vertical Co/Axial Terminal Dimensions

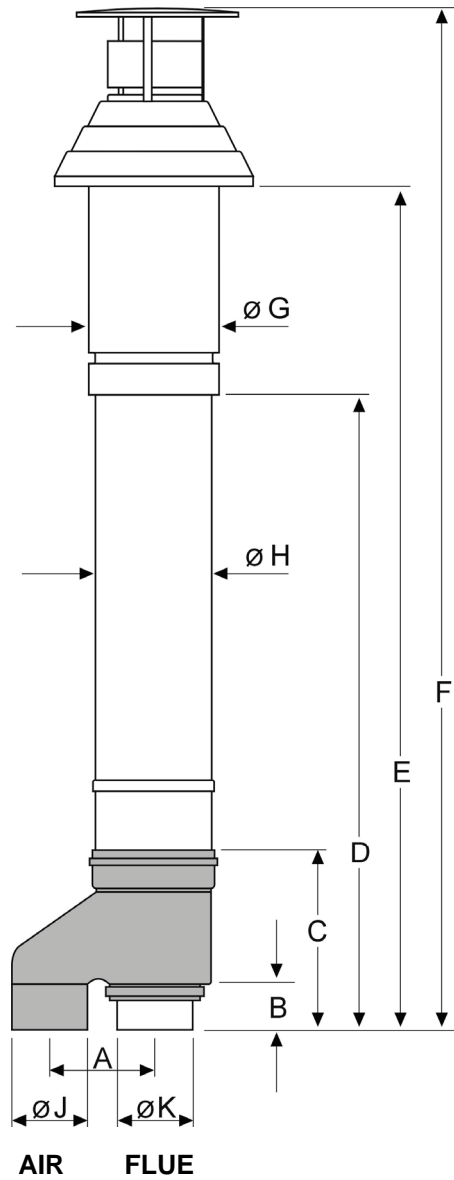

Heater	A	B	C	D	E	F	G	H	J	K
250- 490	225	85	330	900	1630	1860	210	200	130	130

Dimensions in mm's

Horizontal Co/Axial Terminal Dimensions

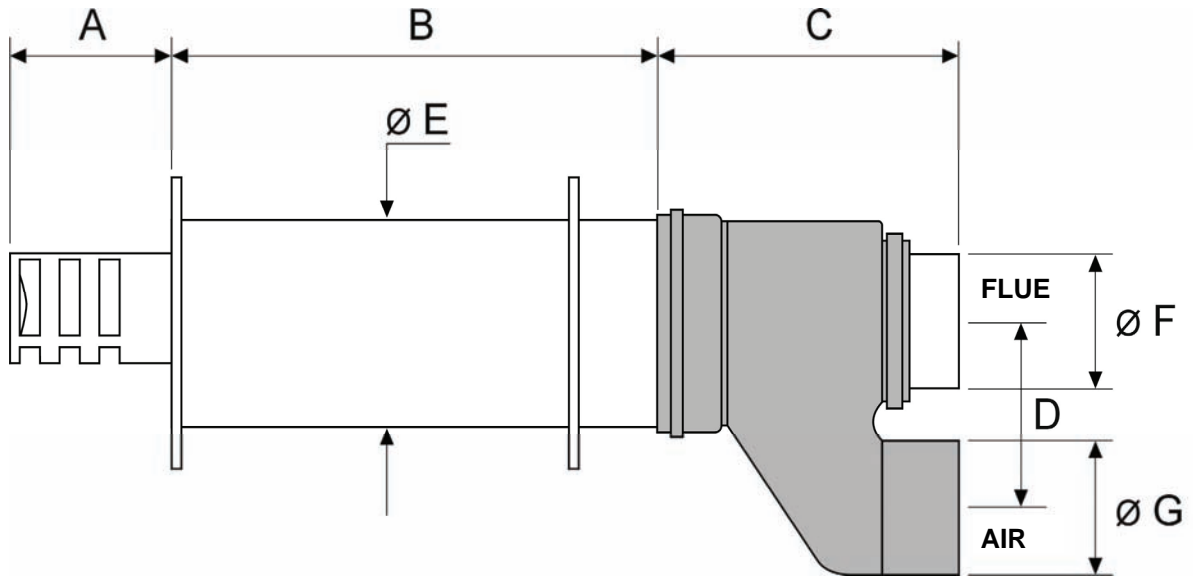

TOP

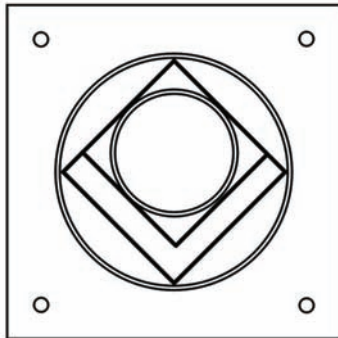

BOTTOM

↑
UP

Ensure Terminal is located on the wall in this configuration

Heater	A	B	C	D	E	F	G	B+C
250-490	180	420	340	225	200	130	130	750

Dimensions in mm's



**BENSON
HEATING**

**BENSON HEATING
LUDLOW ROAD
KNIGHTON
POWYS
LD7 1LP**

Telephone +44 (0) 1547 528534
Facsimile +44 (0) 1547 520399
email information@bensoheating.co.uk
Web www.bensoheating.com