



LEO AGRO

Fan heaters for agricultural
and special purposes buildings



Wide range

CHICKEN FARMS



LEO AGRO HT

LEO AGRO SP

LEO AGRO



New!



	LEO AGRO HT	LEO AGRO SP	LEO AGRO
heating capacity [kW]	18-170	8,7-56,2	6,6-43
air flow [m³h]	10 000	4600	3700
range [m]	54	28	22
installation	vertical/horizontal	vertical/horizontal	vertical
power supply [V]	3x400	230	230



of units

PIGGERIES

GREENHOUSES, CAR WASHES, POOLS



LEO AGRO HT

LEO AGRO HP

LEO AGRO CR

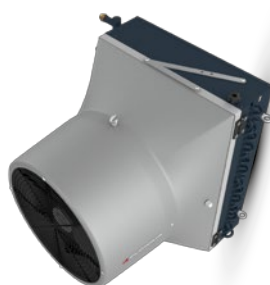

New!

	LEO AGRO HT	LEO AGRO HP	LEO CR
heating capacity [kW]	18–170	8,7–56,2	8,1–52
air flow [m³h]	10 000	4600	3500
range [m]	54	28	20
installation	vertical/horizontal	vertical/horizontal	horizontal
power supply [V]	3x400	230	230



LEO AGRO – general characteristic

RELIABILITY

Appropriate construction, durable materials together with high-end components ensure long-lasting and effective unit operation in severe conditions of agrarian buildings.



HIGHLY-EFFICIENT FAN

Waterproof and dustproof fan with IP66 protection degree and compression ratio allows to save nominal efficiency regardless even low amount of dust.

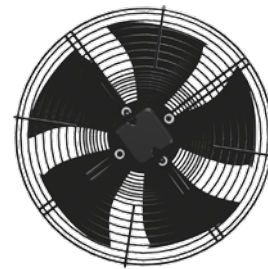

HEAT EXCHANGER

This item has strengthened fins with increased spacing between them, protected by special anti-corrosion coating, resistant to e.g. ammonia, extends the life of the unit.

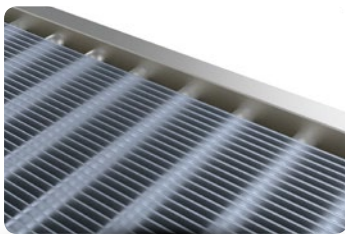

EASY CLEANING

Easy access to unit's interior makes the maintenance and service operations faster. Hinged construction and blocking system enables to mix the air without pressing it through heat exchanger.



6-SIDE AIR OUTLET

Use of diffuser enables steady air distribution in entire volume of the room. Warm air stream is not directed directly on animals.



ROTARY CONSOLE

Enables rotation of the unit and to install it on vertical surfaces, poles, pillars, etc.





Water heaters **LEO AGRO HT**



Water heaters **LEO AGRO HT**

	LEO AGRO HT 50	LEO AGRO HT 75
Heating capacity [kW]	18–116	28–170
Air flow [m³/h]	10 000	
Weight [kg]	76	88
Colour	red-black (RAL 3020 and RAL 9005)	
Casing	plastic	

Characteristic:

LEO AGRO HT

Heater in plastic casing with long heating range and with heat exchanger protected by anti-corrosive coating. Hinged construction enables you to mix the air in summer. Quick access to the unit's interior thanks to buckles, which fasten the heat exchanger with confuser. Dust-proof and waterproof IP66 fan.

Application:

Big cubature buildings with considerable pollution of the air with solid particles, high humidity or corrosive environment.

Dedicated to:

Chicken farms, piggeries

Technical data

	AGRO HT 50	AGRO HT 75
Air flow [m³/h]	10 000	
Power supply [V/Hz]	3x400/50	
Max. current consumption [A]	1,4	
Max. power consumption [W]	560	
IP	66	
Max. acoustic pressure level ⁽¹⁾ [dB(A)]	66	
Max. air stream range ⁽²⁾ [m]	54	
Max. heating water temperature [°C]	95	
Max. operating pressure [MPa]	1,6	
Weight of unit [kg]	76	88
Weight of unit filled with water [kg]	86	104
Connector	1"	

⁽¹⁾ Acoustic pressure level at the distance of 5 m from the unit, in the room of medium capability of sound absorption and 1500 m³ of cubature

⁽²⁾ Range of horizontal isothermal air stream, at 0,5 m/s velocity limit

Dimensions

LEO AGRO HT

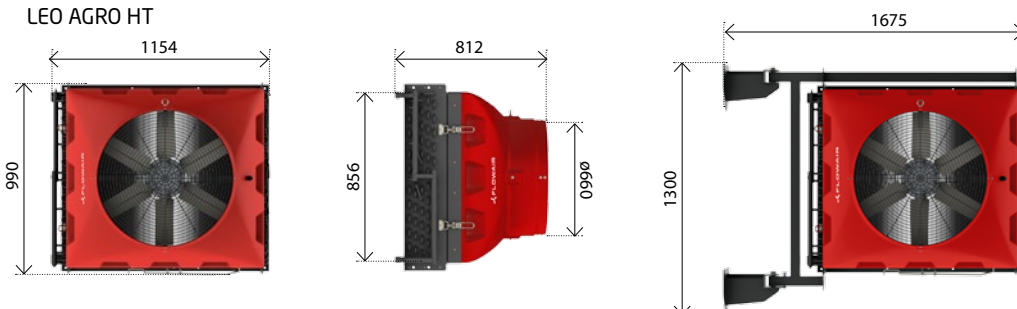



Installation

installation under the ceiling⁽¹⁾

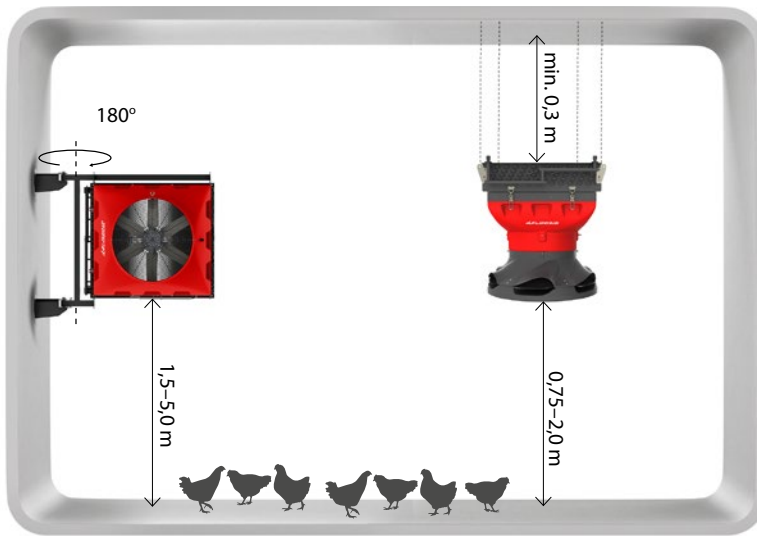

vertical installation using the console



Rotary console
LEO AGRO HT

Rotary consoles enables 180° rotation of the device which lets you direct the air stream in any direction. Additionally, the console ensures easy access to the unit from any side.

⁽¹⁾ Installation under the ceiling of LEO AGRO HT with air outlet

Heating capacities

		Tw1/Tw2 = 90/70°C				Tw1/Tw2 = 80/60°C				Tw1/Tw2 = 70/50°C				Tw1/Tw2 = 60/40°C				Tw1/Tw2 = 50/40°C			
Tp1	PT	Qw	Δpw	Tp2	PT	Qw	Δpw	Tp2	PT	Qw	Δpw	Tp2	PT	Qw	Δpw	Tp2	PT	Qw	Δpw	Tp2	
°C	kW	l/h	kPa	°C	kW	l/h	kPa	°C	kW	l/h	kPa	°C	kW	l/h	kPa	°C	kW	l/h	kPa	°C	
LEO AGRO HT 75 = 10 000 m³/h																					
0	170	7515	138	47,2	149	6510	110	41,1	127	5517	83,4	35	105	4534	60	28,9	94,7	8200	180	26,2	
5	158	6962	120	49,5	136	5971	93,5	43,4	115	4992	69,3	37,3	92,7	4021	48,2	31,1	83,1	7195	142	28,4	
10	146	6421	104	51,8	124	5444	79	45,6	103	4478	56,9	39,5	81,1	3518	37,8	33,3	71,8	6212	109	30,6	
15	134	5892	88,6	54	112	4929	65,9	47,8	91,2	3974	45,8	41,6	69,7	3024	28,7	35,3	60,7	5253	79,8	32,7	
20	122	5375	74,9	56,2	101	4424	54	49,9	79,8	3489	35,9	43,7	58,4	2535	20,8	37,3	49,8	4311	55,6	34,8	
25	110	4868	62,5	58,3	89,6	3929	43,5	52	68,7	2994	27,3	45,7	47,2	2050	14,1	39,2	39,1	3384	35,7	36,8	
30	99,1	4371	51,3	60,4	78,5	3442	34,2	54,1	57,6	2513	19,8	47,7	35,9	1559	8,5	41	28,5	2464	20	38,7	
35	88,1	3883	41,3	62,4	67,6	2963	26	56	46,7	2035	13,5	49,5	24	1041	4,1	42,5	17,7	1530	8,4	40,5	
LEO AGRO HT 50 = 10 000 m³/h																					
0	116	5099	46,9	32	100	4394	36,7	27,8	84,8	3699	27,5	23,5	69,4	3010	19,4	19,2	64,2	5556	60,6	17,8	
5	107	4722	40,7	35,2	91,9	4027	31,2	30,9	76,6	3340	22,8	26,6	61,3	2660	15,4	22,3	56,2	4865	47,5	20,8	
10	98,7	4352	35	38,3	83,7	3667	26,3	34	68,5	2988	18,6	29,7	53,4	2316	12	25,3	48,4	4189	36,1	23,9	
15	90,5	3990	29,8	41,4	75,6	3313	21,8	37,1	60,6	2643	14,8	32,7	45,6	1977	9	28,3	40,7	3525	26,3	26,9	
20	82,4	3634	25,1	44,5	67,7	2966	17,8	40,1	52,8	2303	11,5	35,7	37,8	1642	6,4	31,2	33,2	2873	18	29,8	
25	74,5	3285	20,9	47,5	59,9	2625	14,2	43,1	45,2	1969	8,6	38,6	30,2	1309	4,2	34,1	25,8	2232	11,3	32,8	
30	66,7	2942	17	50,5	52,2	2289	11,1	46	37,6	1638	6,2	41,5	22,5	974	2,5	36,9	18,4	1596	6,2	35,6	
35	59,1	2605	13,6	53,4	44,7	1958	8,3	48,9	30	1308	4,1	44,3	14,4	623	1,1	39,5	11	953	2,4	38,4	

To obtain operating parameters concerning other water temperatures please contact Sales Office.

- V – air flow
- PT – heating capacity
- Tp1 – inlet air temperature
- Tp2 – outlet air temperature
- Tw1 – inlet water temperature
- Tw2 – outlet water temperature
- Qw – water stream flow in the heat exchanger
- Δpw – water pressure drop in the heat exchanger



LEO AGRO HT Accessories

AGRO HT 6-SIDE AIR OUTLET

Material: plastic

Weight: 8,6 kg

AGRO SP 6-side air outlet distributes the air when heater is installed under the ceiling

Benefits of using AGRO HT 6-side air outlet:

- steady temperature distribution,
- better quality of bedding,
- lower concentration of ammonia,
- lower level of humidity in the room.

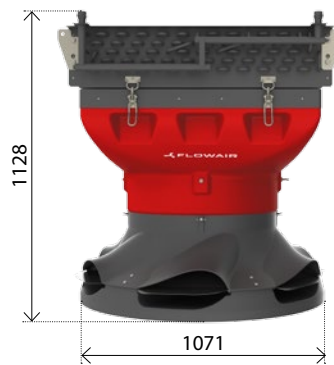

LEO AGRO HT + AIR OUTLET

Air flow zone

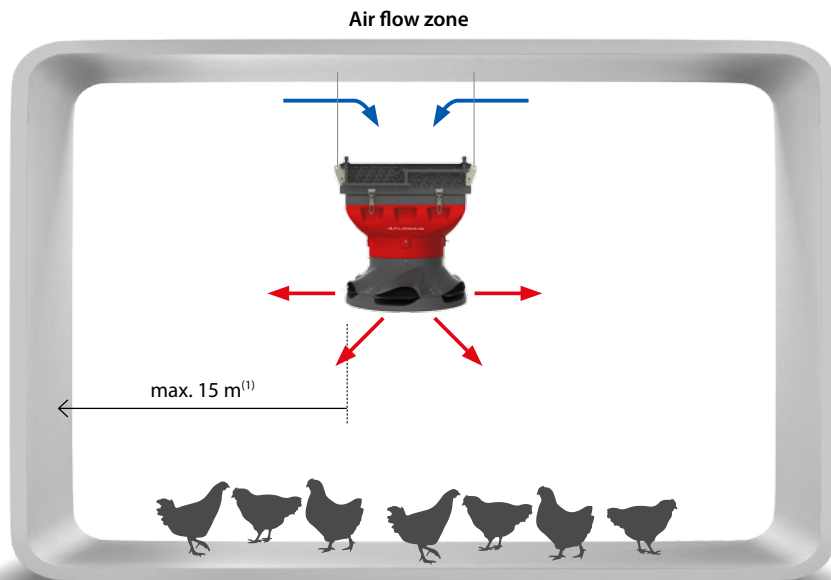

⁽¹⁾ Range of horizontal isothermal air stream, at 0,5 m/s velocity limit

Control system

Description of the control system is on page 15.

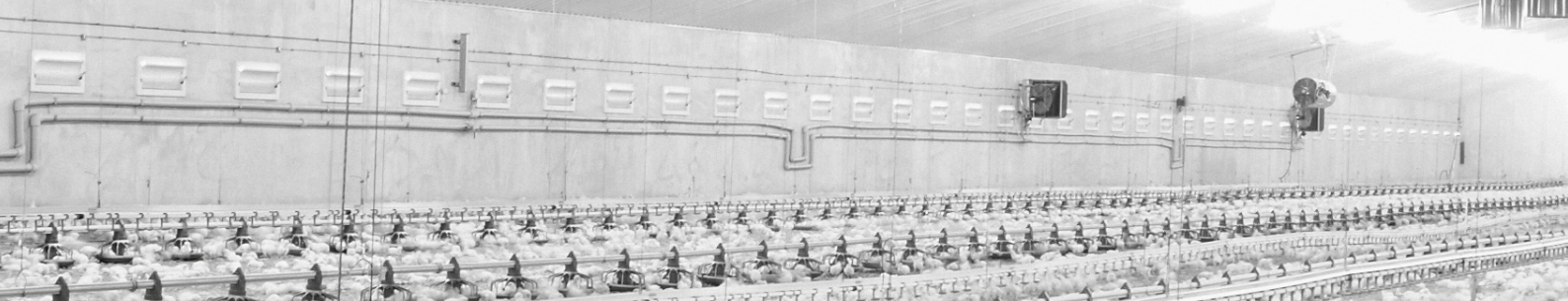

Water heaters **LEO AGRO**



Water heaters **LEO AGRO**

Heating capacity [kW]	6,6–43
Air flow [m³/h]	1900–3700
Weight [kg]	21,8–23,9
Colour	grey
Casing	powder-painted steel with anti-corrosive coating.

Characteristic:

Heater with epoxidized heat exchanger in casing made of galvanized steel protected by anti-corrosive coating. It has adjustable handlebars and easily removable drip tray with drain plug allows simple cleaning.

Application:

Dedicated for medium and big cubature buildings with considerable pollution of the air with solid particles, high humidity or corrosive environment.

Dedicated to:

Chicken farms

Technical data

	AGRO
Air flow [m³/h]	3700
Power supply [V/Hz]	230/50
Max. current consumption [A]	1,8
Max. power consumption [W]	350
IP	66
Max. acoustic pressure level ⁽¹⁾ [dB(A)]	51
Max. air stream range ⁽²⁾ [m]	22
Max. heating water temperature [°C]	130
Max. operating pressure [MPa]	1,6
Weight of unit [kg]	21,8
Weight of unit filled with water [kg]	23,9

⁽¹⁾ Acoustic pressure level at the distance of 5 m from the unit, in the room of medium capability of sound absorption and 1500 m³ of cubature

⁽²⁾ Range of horizontal isothermal air stream, at 0,5 m/s velocity limit

Dimensions

LEO AGRO

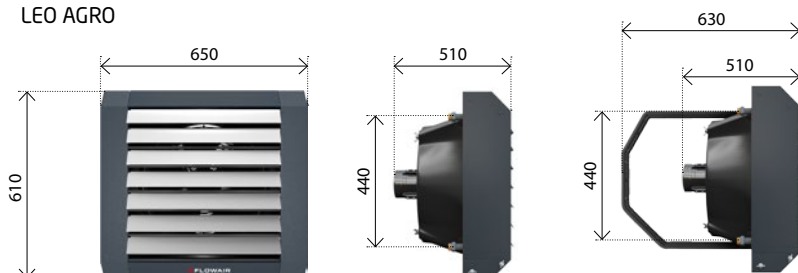



Installation

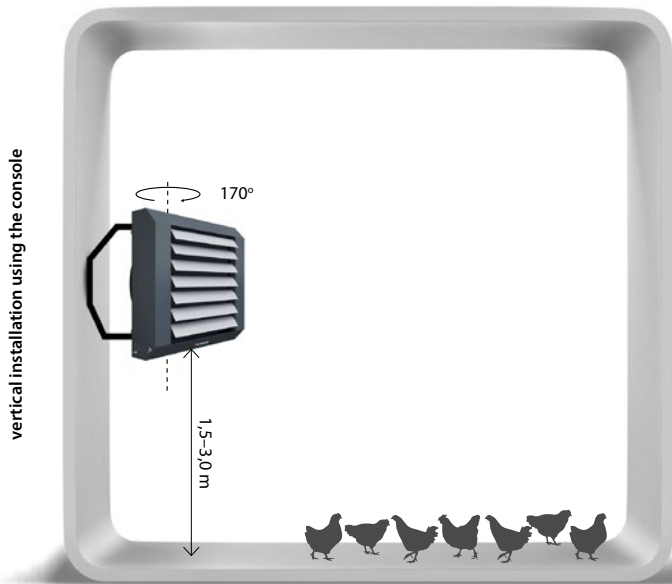

vertical installation using the console

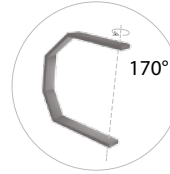

Rotary console

Rotary consoles enables 170° rotation of the device which lets you direct the air stream in any direction. Additionally, the console ensures easy access to the unit from any side.

Heating capacities

Tp1 °C	Tw1/Tw2 = 90/70°C				Tw1/Tw2 = 80/60°C				Tw1/Tw2 = 70/50°C				Tw1/Tw2 = 60/40°C				Tw1/Tw2 = 50/40°C			
	PT kW	Qw l/h	Δpw kPa	Tp2 °C	PT kW	Qw l/h	Δpw kPa	Tp2 °C	PT kW	Qw l/h	Δpw kPa	Tp2 °C	PT kW	Qw l/h	Δpw kPa	Tp2 °C	PT kW	Qw l/h	Δpw kPa	Tp2 °C
LEO AGRO = 3700 m³/h																				
0	43,0	1890	20,0	32,5	37,2	1630	16,0	28,0	31,3	1370	13,0	23,5	25,4	1110	11,0	19,0	23,8	2070	26,0	18,0
5	39,7	1750	17,0	35,5	34,0	1490	15,0	31,0	28,2	1230	11,0	26,5	22,4	980	9,0	22,0	20,8	1810	21,0	21,0
10	36,6	1610	15,0	38,5	30,9	1360	13,0	34,0	25,1	1100	10,0	29,5	19,4	840	7,0	25,0	17,8	1550	18,0	24,0
15	33,5	1470	15,0	41,5	27,8	1220	11,0	37,0	22,2	970	8,0	32,5	16,4	720	7,0	28,0	15,0	1300	13,0	27,0
20	30,4	1340	12,0	44,5	24,9	1090	10,0	40,0	19,2	840	6,0	35,5	13,5	590	5,0	31,0	12,1	1050	10,0	30,0
25	27,5	1210	10,0	47,5	21,9	960	8,0	43,0	16,3	710	6,0	38,5	10,7	460	5,0	34,0	9,3	810	6,0	33,0
30	24,5	1080	10,0	50,5	19,1	840	6,0	46,0	13,5	590	5,0	41,5	7,8	340	3,0	36,5	6,6	570	4,0	35,5
35	21,7	950	8,0	53,5	16,2	710	6,0	49,0	10,7	470	5,0	44,0	4,8	210	3,0	39,0	3,8	330	3,0	38,0

To obtain operating parameters concerning other water temperatures please contact Sales Office.

- V – air flow
- PT – heating capacity
- Tp1 – inlet air temperature
- Tp2 – outlet air temperature
- Tw1 – inlet water temperature
- Tw2 – outlet water temperature
- Qw – water stream flow in the heat exchanger
- Δpw – water pressure drop in the heat exchanger

Control system

Description of the control system is on page 15.

Accessories LEO AGRO

Mixing chamber KM L is available to the heater LEO AGRO used to provide fresh air into the room.



Water heaters **LEO AGRO SP/HP**



LEO AGRO SP

LEO AGRO HP

Water heaters **LEO AGRO SP/HP**

Heating capacity [kW]	8,7–56,2
Air flow [m ³ /h]	3300–4600
Weight [kg]	27,3–31,0
Colour	grey
Casing	plastic

Characteristic:

LEO AGRO SP/HP

Heater with epoxidized heat exchanger (LEO AGRO SP) protected by anti-corrosive coating (LEO AGRO HP). Long air stream range in casing made of plastic. All joint parts made of stainless steel. Hinged construction enables you to mix the air in summer. Quick access to the unit's interior thanks to buckles, which fasten the heat exchanger with confusor. Dustproof and waterproof IP66 fan.

Application:

Dedicated for medium and big cubature buildings with considerable pollution of the air with solid particles, high humidity or corrosive environment.

Dedicated for:

LEO AGRO SP: chicken farms

LEO AGRO HP: piggeries

Technical data

	AGRO SP/HP
Air flow [m ³ /h]	4600
Power supply [V/Hz]	230/50
Max. current consumption [A]	2,5
Max. power consumption [W]	360
IP	66
Max. acoustic pressure level ⁽¹⁾ [dB(A)]	62
Max. air stream range ⁽²⁾ [m]	28
Max. heating water temperature [°C]	95
Max. operating pressure [MPa]	1,6
Weight of unit [kg]	27,3
Weight of unit filled with water [kg]	31,0

⁽¹⁾ Acoustic pressure level at the distance of 5 m from the unit, in the room of medium capability of sound absorption and 1500 m³ of cubature

⁽²⁾ Range of horizontal isothermal air stream, at 0,5 m/s velocity limit

Dimensions

LEO AGRO SP/HP

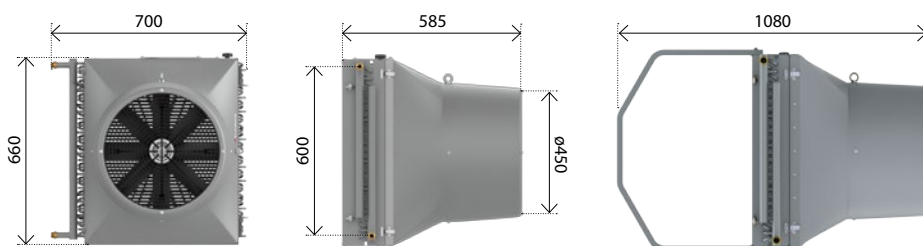



Installation

installation under the ceiling⁽¹⁾

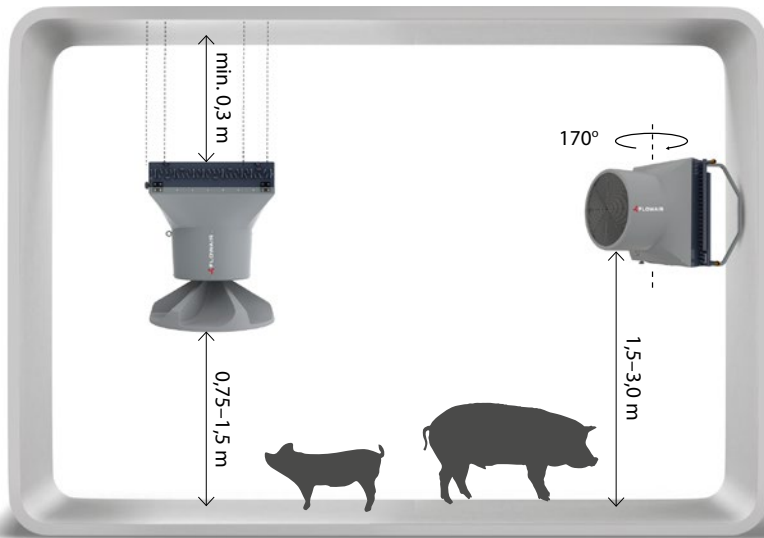

vertical installation using the console

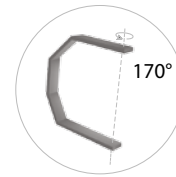

Rotary console LEO AGRO SP/HP

For wall-mounting, a rotary console is available. Rotary consoles enables 170° rotation of the device which lets you direct the air stream in any direction. Additionally, the console ensures easy access to the unit from any side.

⁽¹⁾ Fan heaters for agricultural buildings and special purposes

Heating capacities

Tp1 °C	Tw1/Tw2 = 90/70°C				Tw1/Tw2 = 80/60°C				Tw1/Tw2 = 70/50°C				Tw1/Tw2 = 60/40°C				Tw1/Tw2 = 50/40°C			
	PT kW	Qw l/h	Δpw kPa	Tp2 °C	PT kW	Qw l/h	Δpw kPa	Tp2 °C	PT kW	Qw l/h	Δpw kPa	Tp2 °C	PT kW	Qw l/h	Δpw kPa	Tp2 °C	PT kW	Qw l/h	Δpw kPa	Tp2 °C
LEO AGRO SP/HP = 4600 m³/h																				
0	56,2	2480	21,0	34,0	48,6	2140	16,0	29,5	41,0	1800	12,0	25,0	33,4	1450	10,0	20,5	31,2	2710	26,0	19,0
5	52,0	2290	18,0	37,0	44,5	1950	14,0	32,5	36,9	1620	10,0	28,0	29,4	1280	8,0	23,0	27,2	2370	21,0	22,0
10	47,8	2110	16,0	40,0	40,4	1780	12,0	35,5	33,0	1440	10,0	31,0	25,5	1110	8,0	26,0	23,4	2030	16,0	24,5
15	43,8	1930	13,0	43,0	36,4	1600	10,0	38,5	29,1	1270	8,0	33,5	21,6	940	6,0	29,0	19,6	1710	12,0	27,5
20	39,8	1750	11,0	46,0	32,6	1430	10,0	41,0	25,3	1110	8,0	36,5	17,9	780	4,0	31,5	15,9	1380	10,0	30,5
25	35,9	1580	9,0	49,0	28,7	1260	8,0	44,0	21,5	940	6,0	39,5	14,1	610	4,0	34,5	12,3	1070	7,0	33,0
30	32,1	1420	9,0	51,5	25,0	1100	7,0	47,0	17,8	780	4,0	42,0	10,3	450	4,0	37,0	8,7	750	6,0	36,0
35	28,4	1250	7,0	54,5	21,3	940	5,0	49,5	14,1	620	4,0	44,5	6,4	280	2,0	39,5	5,0	440	4,0	38,5

To obtain operating parameters concerning other water temperatures please contact Sales Office.

- V – air flow
- PT – heating capacity
- Tp1 – inlet air temperature
- Tp2 – outlet air temperature
- Tw1 – inlet water temperature
- Tw2 – outlet water temperature
- Qw – water stream flow in the heat exchanger
- Δpw – water pressure drop in the heat exchanger



LEO AGRO SP/HP Accessories

AGRO SP/HP 6-SIDE AIR OUTLET

Material: plastic

Weight: 1,6 kg

AGRO SP 6-side air outlet distributes the air when heater is installed under the ceiling.

Benefits of using AGRO SP 6-side air outlet:

- steady temperature distribution,
- better quality of bedding,
- lower concentration of ammonia,
- lower level of humidity in the room.

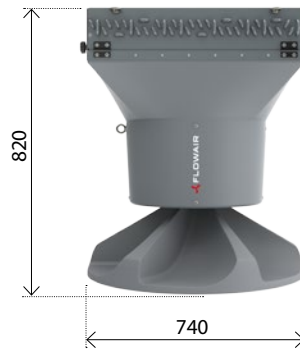

LEO AGRO SP + AIR OUTLET

Air flow zone

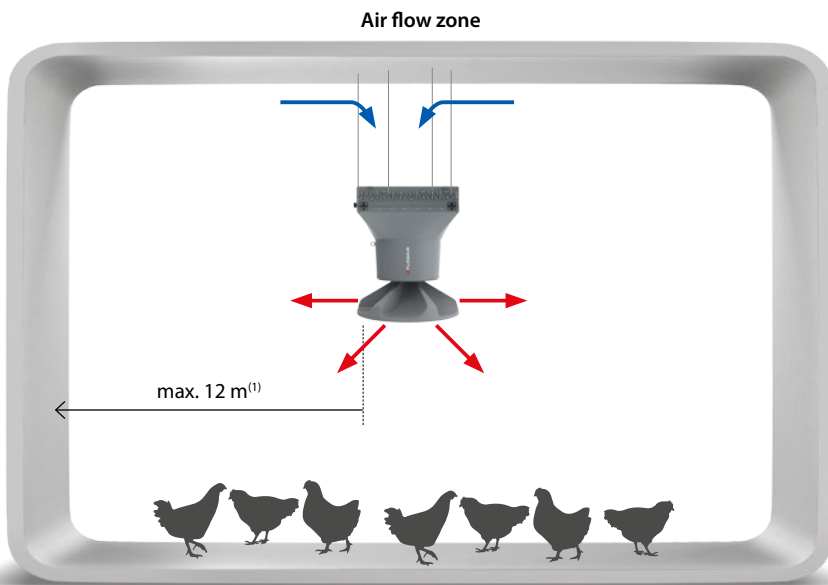

⁽¹⁾ Range of horizontal isothermal air stream, at 0,5 m/s velocity limit

Control system

Description of the control system is on page 15.



Water heaters **LEO AGRO CR**



Water heaters **LEO AGRO CR**

Heating capacity [kW]	8,1–52
Air flow [m ³ /h]	1800–3500
Weight [kg]	27–29,3
Colour	grey
Casing	plastic

Characteristic:

LEO AGRO CR

Heater with epoxidized heat exchanger protected by anti-corrosive coating in casing made of plastic. Dustproof and waterproof IP66 fan.

Application:

Dedicated for medium and big cubature buildings with considerable pollution of the air with solid particles, high humidity or corrosive environment.

Dedicated for:

Greenhouses, car washes, pools.

Technical data

	AGRO CR
Air flow [m ³ /h]	3500
Power supply [V/Hz]	230/50
Max. current consumption [A]	1,8
Max. power consumption [W]	350
IP	66
Max. acoustic pressure level ⁽¹⁾ [dB(A)]	51
Max. air stream range ⁽²⁾ [m]	20
Max. heating water temperature [°C]	95
Max. operating pressure [MPa]	1,6
Weight of unit [kg]	27
Weight of unit filled with water [kg]	29,3

⁽¹⁾ Acoustic pressure level at the distance of 5 m from the unit, in the room of medium capability of sound absorption and 1500 m³ of cubature

⁽²⁾ Range of horizontal isothermal air stream, at 0,5 m/s velocity limit

Dimensions

LEO AGRO CR

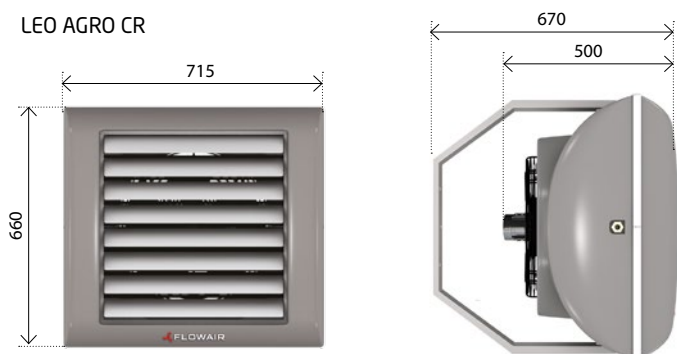



Installation

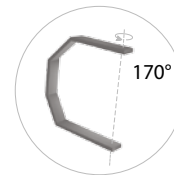
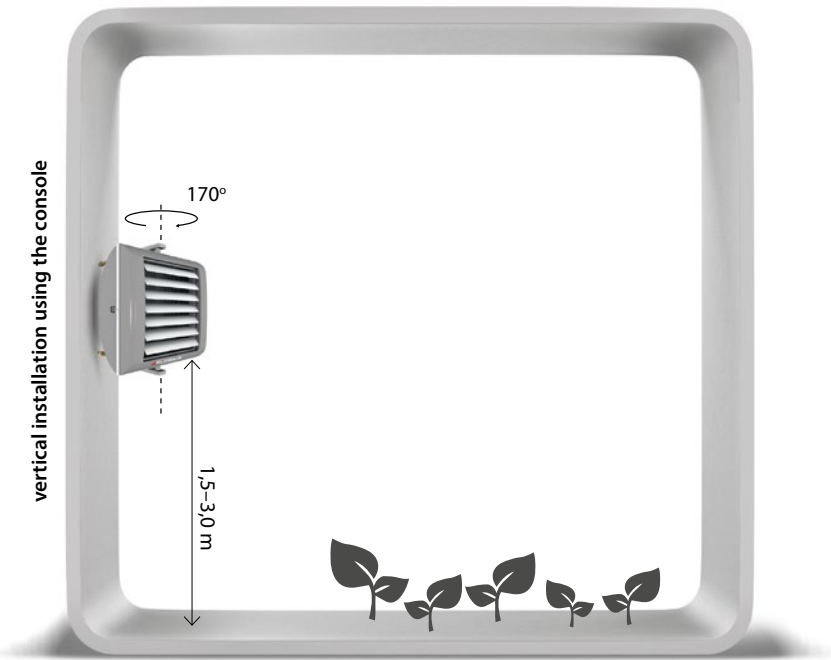

Rotary console

Rotary consoles enables 170° rotation of the device which lets you direct the air stream in any direction. Additionally, the console ensures easy access to the unit from any side.

Heating capacities

Tp1 °C	Tw1/Tw2 = 90/70°C				Tw1/Tw2 = 80/60°C				Tw1/Tw2 = 70/50°C				Tw1/Tw2 = 60/40°C				Tw1/Tw2 = 50/40°C			
	PT kW	Qw l/h	Δpw kPa	Tp2 °C	PT kW	Qw l/h	Δpw kPa	Tp2 °C	PT kW	Qw l/h	Δpw kPa	Tp2 °C	PT kW	Qw l/h	Δpw kPa	Tp2 °C	PT kW	Qw l/h	Δpw kPa	Tp2 °C
LEO AGRO CR = 3500 m³/h																				
0	52,1	2300	31,0	41,5	45,1	1980	24,0	36,0	38,1	1670	18,0	30,5	31,1	1350	14,0	24,5	28,9	2510	40,0	23,0
5	48,2	2120	27,0	44,0	41,3	1810	21,0	38,5	34,3	1500	17,0	33,0	27,4	1190	11,0	27,0	25,2	2200	32,0	25,5
10	44,3	1950	23,0	46,5	37,5	1650	17,0	41,0	30,7	1340	14,0	35,5	23,8	1040	10,0	29,5	21,7	1890	24,0	28,0
15	40,6	1790	20,0	49,0	33,8	1490	16,0	43,5	27,1	1180	11,0	37,5	20,2	880	8,0	32,0	18,2	1580	17,0	30,0
20	36,9	1630	16,0	51,5	30,2	1330	13,0	46,0	23,5	1030	10,0	40,0	16,7	730	7,0	34,0	14,8	1280	13,0	32,5
25	33,3	1470	15,0	54,0	26,7	1170	11,0	48,0	20,0	880	7,0	42,5	13,2	580	5,0	36,5	11,4	990	10,0	35,0
30	29,8	1310	13,0	56,5	23,3	1020	9,0	50,5	16,6	730	7,0	44,5	9,7	420	5,0	38,5	8,1	710	7,0	37,0
35	26,3	1160	10,0	58,5	19,8	870	7,0	53,0	13,2	580	5,0	47,0	6,0	260	2,0	40,5	4,7	410	5,0	39,5

To obtain operating parameters concerning other water temperatures please contact Sales Office.

- V – air flow
- PT – heating capacity
- Tp1 – inlet air temperature
- Tp2 – outlet air temperature
- Tw1 – inlet water temperature
- Tw2 – outlet water temperature
- Qw – water stream flow in the heat exchanger
- Δpw – water pressure drop in the heat exchanger



Control systems

Water heaters AGRO | AGRO SP/HP | AGRO CR | AGRO HT

ON/OFF REGULATION

Fan heater is controlled by room thermostat, which turns on the unit when measured temperature drops below a set temperature.

Features:

- low thermal inertia,
- low investment costs,
- easy to use,
- independent regulation of every single unit,
- gradual regulation of air flow.

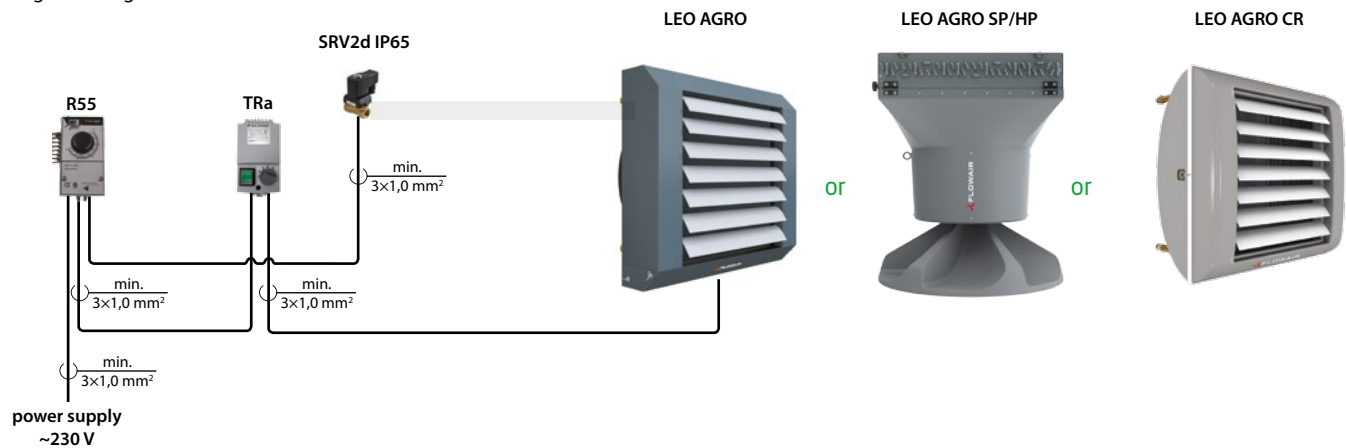

R55 thermostat controls SRQ2d valve,
TRa fan speed regulator enables 5-step fan speed regulation,

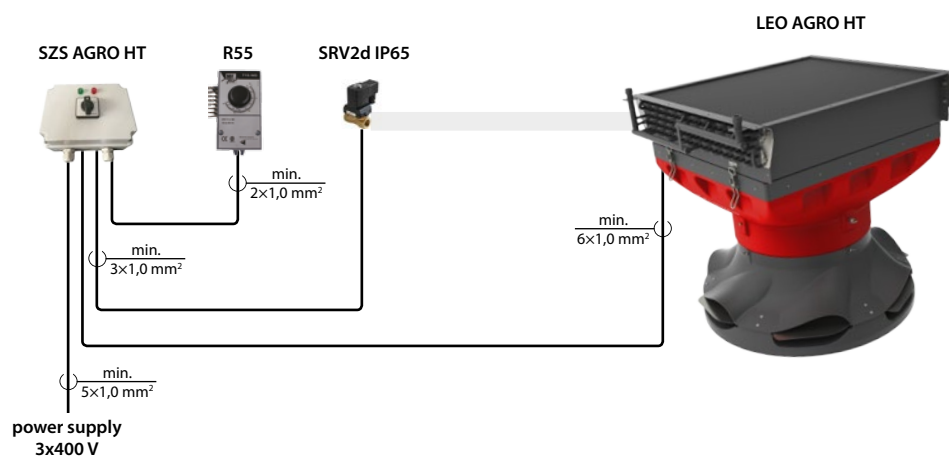

R55 thermostat controls valve through SZS AGRO HT.

Features of SZS AGRO HT:

- change the direction of rotation of the fan (L/R),
- on/off regulation,
- work and failure signalisation,
- security the wrong phase sequency, assymetry and backup phase.

Possible units regulation with microclimate controller (beyond FLOWAIR offer).

Find out more

Call for more information

+48 510 086 994

charge as per call by call unit



gas heaters

ductless ventilation
with heat recovery

air curtains and air curtain-fan
heater combo units

air heating and ventilation

Check out YouTube channel

watch movies!



Visit our website

www.flowair.com

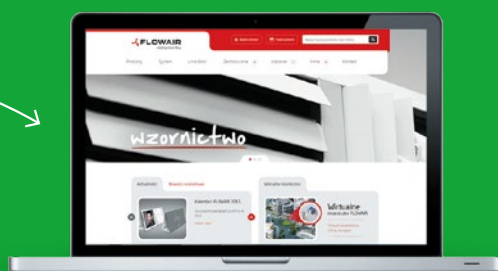

FLOWAIR

ul. Chwaszczyńska 151E,
81-571 Gdynia

Tel. +48 58 627 57 20
Fax. +48 58 627 57 21
Mobile: +48 510 086 994

inquiries should be directed to the
following address:
agro@flowair.pl