

®

YACH



TECHNICAL MANUAL

CE 1312BO3962

GAS AIR CURTAIN YAC H

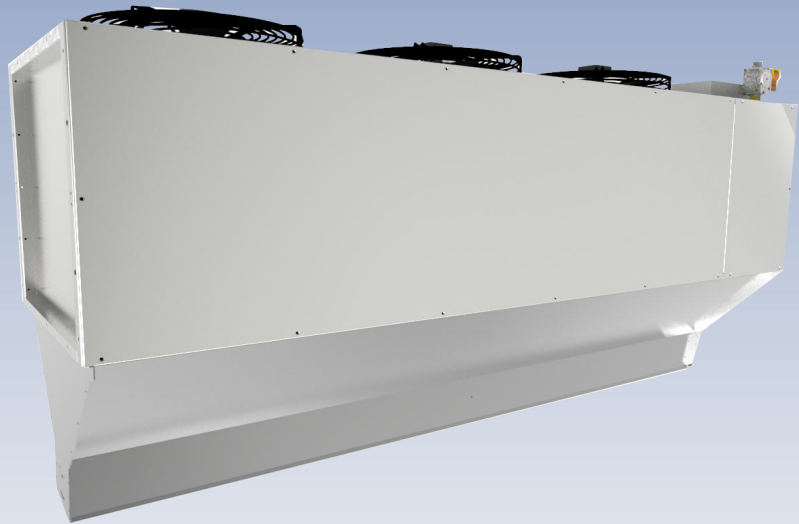

TABLE OF CONTENTS

Section N°	Sections	Pages
1	GENERAL RECOMMENDATIONS 1-1 Description of devices 1-2 Instruction for use 1-3 Operating 1-4 Safety 1-5 Cut-off 1-6 Guarantee	5-6
2	TECHNICAL PERFORMANCES OF GAS AIR CURTAINS	7
3	GAS AIR CURTAIN INSTALLATION 3-1 Mounting 3-2 Inversion of a diffusor 3-3 Wall brackets	8-9
4	FLUE CONNECTION 4-1 General information 4-2 Connection of sealed roof chimney type B22 4-3 Concentric connection	9-10
5	ELECTRICAL WIRING 5-1 Electrical diagram for YAC35H 5-2 Electrical diagram for YAC45H	11-12
6	GAS CIRCUIT 6-1 Changing gas 6-2 Valve adjustment table 6-3 Gas connection	13-14
7	COMMISSIONING OF GAS AIR CURTAINS 7-1 Operating principal 7-2 Bill of material	15-17
8	TROUBLE SHOOTING	18
9 9-1 9-2	RECOMMENDATIONS FOR USER Maintenance Precautions to be respected	19

© Copyright

This range of products are constantly being updated and refined. We reserve the right to change our products and their relevant technical data contained in this publication at any time and without prior notice.

NOTICE

CE marking

Concerning the technical demands that are required, the CE marking is the official recognition of the quality of design, manufacture and performance of this device. Its long lifetime and its performance will be at optimum level if its use and its maintenance are properly carried out and the regulations in force.

Responsibility

This equipment must be used expressly for the purpose for which **YAHEC** has designed and manufactured it. Any contractual liability of **YAHEC** is therefore excluded in case of damage undergone by persons, animals or goods, following errors in installation, settings, maintenance and inappropriate use.

The devices must be equipped exclusively with genuine accessories. **YAHEC** will not be held responsible for any damage whatsoever arising from the use of an accessory which is inappropriate to the device.

The devices must be installed by qualified professional workers, respecting the regulations and decrees in force, and in accordance with the instructions shown in this instruction manual. The installer is required to establish installation conformity certificates produced by the ministries responsible for the construction and safety of gas. References to standards, rules and directives mentioned in this manual are given for information purposes and are only valid at the date of printing this manual.

YAHEC is responsible for the conformity of the device to the rules, directives and standards of construction in force at the time of marketing. Knowledge and respect for the legal provisions as well as the standards inherent in the design, implantation, installation, commissioning and maintenance are exclusively the responsibility of the study bureau, of the installer and of the user.

Reception – Storage

The gas air curtain is delivered on a wooden pallet, protected by cardboard packing and a plastic film. It is essential to check the condition of the equipment delivered (even if the packing is intact) and its conformity compared to the order.

In case of damage or missing parts, you must report the observations on the transport company's receipt form in the most precise way possible, "subject to unpacking" has no legal value, and then you must confirm those reservations by registered letter within 48h to the transport company. We remind you that it is the responsibility of the buyer to check the delivered merchandise, no recourse will be possible if this procedure is not respected.

Store the equipment in a clean and dry room, away from shocks, vibration, divergences in temperature and in an ambient environment with a rate of hygrometry lower than 90%.

Handling

Use all necessary protections of accident preventing while unpacking the device. The unpacking of a device must be carried out by a professional person.

1-GENERAL RECOMMENDATIONS

These devices can only be installed in rooms which are sufficiently ventilated, unless the device has a sealed connection.

The correct operation of the unit heater depends on correct installation and commissioning.

If these rules are not observed, the manufacturer will immediately be exempt from any liability.

The installation and maintenance must be carried out in conformity with the regulation text and the current rules of the trade and by qualified personnel.

DO NOT INSTAL THE GAS UNIT HEATER IN:

- Rooms which have a risk of explosion,
- Rooms containing chlorinated combination vapours,
- Rooms with a high content of combustible dust,
- Very humid rooms (electrical danger).
- Domestic rooms.

RECOMMENDATIONS FOR INSTALLATION :

- Provide a minimum distance of 200 mm at the rear of the device "fan side".
- Provide sufficient clearance for opening the burner door.
- The unit heater must be placed at a minimum of 200 mm from the ceiling and 2000 mm from the floor.

After verifying that the assembly respects the requirements of these instructions, it is the responsibility of the installer:

1°) to inform the user :

-that he or she cannot carry out any modifications him or herself to the design of the devices and the manner in which the installation is executed.

-that it is essential to carry out the required cleaning and maintenance operations by a qualified professional person. The frequency of the maintenance operations depends on the environment in which the device is installed. In particular, more regular inspection must be carried out in dusty locations.

2°) to give the user these instructions

YAHITEC, with the agreement of the organisation which has notified the CE marking, reserves the right to update these technical instructions. Only the instructions which accompany the product at its shipment can be considered as contractual; keep the instructions carefully near the device.

1.1 - Description of the device

Gas air curtains YAC H is a generator of a hot air operating with natural gas and propane ; it is in conformity with the 1020 EEC European directive applicable to gas devices .

Gas air curtains YAC H operating with different gas types indicated on the mark plate of the device.

1.2. Instruction for use

- Please read the instructions in this manual carefully for the operation and maintenance of this device.
- Regularly verify that there is no damage to the device, to the chimney or to the gas conduit.
- Regularly verify that the air openings in the building and around the device are not obstructed.
- Verify that the hot air can circulate normally in the room, and therefore that there is no obstacle in front of the blowing outlet of the device, and that the grille is indeed open.

1.3. Operating

- When heat is required, the burner ignites using the ignition electrode then the fan starts to run, the hot air is then blown into the room. When the setting temperature is attained, the burner is extinguished. The fan continues to turn for about one minute, until it has eliminated the heat remaining in the heat exchanger.

1.4. Safety

- If there is no flame, this is detected by an ionization sensor and the gas valves are immediately closed.
- The thermal protection of the heat exchanger is ensured by two thermostats. The first, which is automatically reset, protects against insufficient air flow (obstructions, fan failure). The second, which has to be manually reset, is set to a higher threshold than the first one. It protects the device against high excess heating due to an operating problem or unsuitable use.
If the operation shows any difficulty whatsoever, please contact us.
Make sure that the device can be supplied normally with combustion air at atmospheric pressure (any modification of the building after the installation of the device must be carried out taking this into account). Excessively low pressure inside the room can harm the correct functioning of the device by depriving it of the air necessary for combustion.
The lowest temperature for device functioning is - 10 °C.

1.5. Cut-off

- To cut the device off during a short period, it is necessary only to cut off the thermostatic line (this means turning the thermostat to a minimum setting point or turning off the thermostat switch) .
- For a prolonged stoppage, switch off the thermostatic line, close the gas valve and cut off the electrical supply, taking care to wait for the fan to stop turning.

Gas and electricity must only be cut off in case of emergency or for long stoppage periods.

1.6. Guarantee (An extract from the general sales condition, section GUARANTEE) :

The devices must be installed by qualified professional personnel, in conformity with current regulations, with the rules of the trade and the instructions which are found in our assembly instructions.

The devices are guaranteed 1 year against any manufacturing failure and 5 years for the heat exchangers as long as they are operated using the normal user instructions.

The guarantee takes effect on the date of manufacture by our company and on condition that the guarantee form is returned completed and signed. We decline any responsibility and no guarantee will be applicable in case of negligence of the customer, of defective installation, or installation which is unsuitable or not in conformity with current standards. Only defects in manufacture or raw materials are concerned.

The guarantee is limited to the replacement of parts which are found to be defective by identical parts; costs of labour, travel, transport and excess to the equipment are excluded.

Any replacement which takes place during the guarantee period, even if it necessitates the immobilization of the equipment, cannot in any circumstances extend the duration of the guarantee. No damages or interest can be claimed for direct or indirect prejudice.

It is imperative that the installation, maintenance and any trouble shooting is carried out by qualified professional personnel. Any servicing must be carried out using the rules of the trade and therefore in accordance with current standards and the indications supplied by our company in this manual. The correct operation of the device depends on correct installation and commissioning. Non-respect of the rules will immediately cause our company to refuse any liability.

The devices must only be equipped with the original smoke system and air intake.
In case of use of accessories other than those proposed by our company, check that they are indeed compatible with the devices. Our company will not be responsible for any damage or prejudice resulting from improper use of the devices.

The engineering studies office, the installer and the user are solely responsible for being aware of and respecting the legal provisions as well as the standards which are inherent in the design, location, installation, commissioning and maintenance.

2 - TECHNICAL PERFORMANCES OF GAS-FIRED AIR CURTAINS

Gas-fired air curtains YAC H are specially elaborated for protection against uncontrolled external airflow through the doors or building openings in such places as warehouses, industrial buildings, supermarkets, public places etc.

The range includes 2 models with a diffuser 1.96 m and 2.5 m. According to the height of the door and the power of the wind outside, it will be necessary to choose the right air curtain.

Gas-fired air curtains YAC H are regulated by a door contact.

Performances of gas air curtains

Model		YAC 35 H	YAC 45 H
Nominal power	kW	35	44
Utile power	kW	31.5	40.5
Efficiency	%	91	91
Gaz flow G20 at 15°C	m ³ /h	4.02	4.63
Gaz flow en G25 at 15°C	m ³ /h	4.46	5.17
Gaz flow en G31 at 15°C	kg/h	2.96	3.52
Qty of fans		3 * 380	3 * 450
Rotation speed	Tr/m	1 350 / 1 200	1 350 / 1 050
Air flow at 15 °C, high speed	m ³ /h	6 500	10 500
Air flow 15 °C, low speed	m ³ /h	5 000	8 200
Delta T° of air	° C	16 / 21	12 / 15
Diameter air / fumes	mm	100 / 100	100 / 100
Supply voltage		Single-phase 230V	
Electrical power	kW	0.55	1.35
Diameter of gas connection		3/4" M	3/4" M
Weight without diffuser	kg	134	154
Weight with diffuser	kg	151	173

Dimensions YAC35H

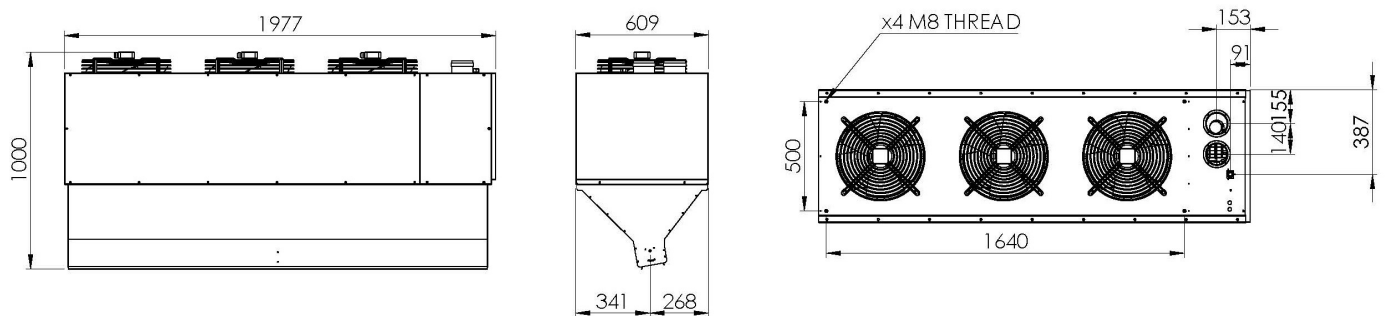

Dimensions YAC45H

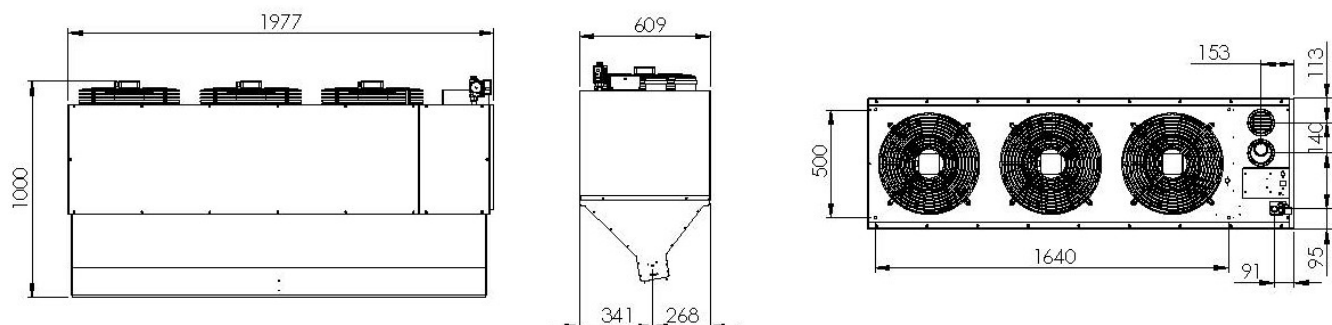

3- GAS-FIRED AIR CURTAINS INSTALLATION

YACH Gas air curtains must be installed horizontally above the opening or a door.

3-1 Mounting

The air curtain must be fixed using brackets, M8 fixation nuts and threaded rods (not supplied). Make sure that the fixation is strong enough and adapted to the weight of the gas air curtain.

While mounting the air curtain, the burner section can be on the right side (picture 1) or on the left side (picture 2) where it is the most accessible. For the installation of two air curtains, placed the burner section from each end, not at the centre.

The gap above the air curtain must be at least 60 cm.

Installation of an air curtain with a diffuser of 2 m

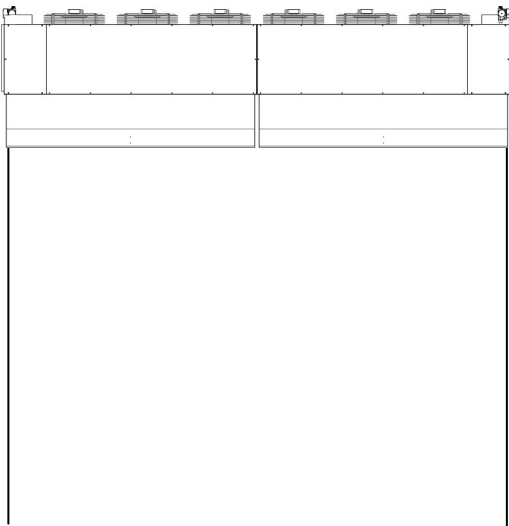

Installation of an air curtain with a diffuser of 2.5 m

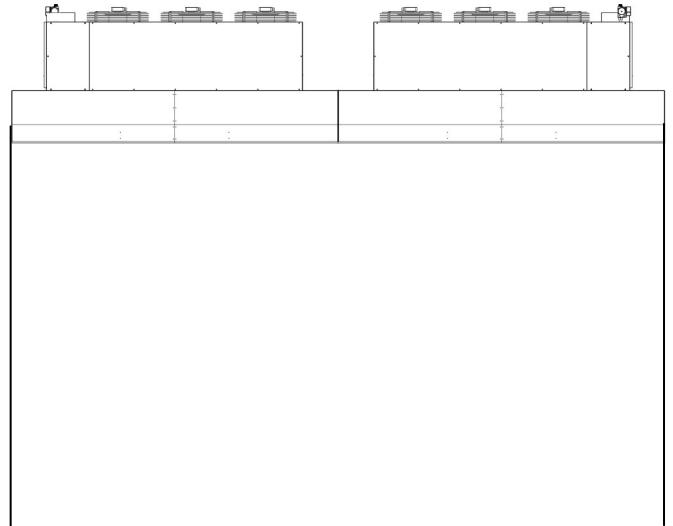

3-2 Inversion of the diffuser

Depending on the mounting it can be necessary to invert the diffuser. In this case, put off the screws, invert the diffuser and fixe it back using the screws.

Picture 1

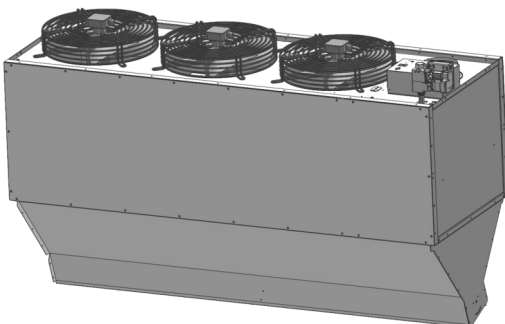

Picture 2

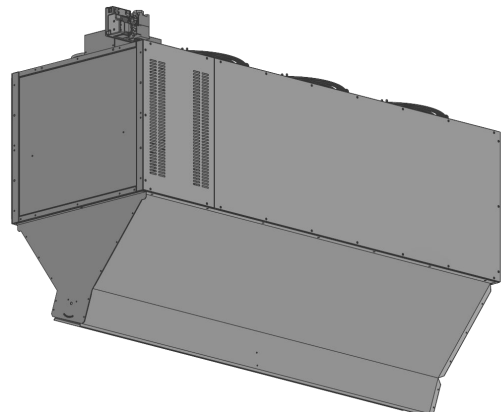

3-3 Wall brackets

Fixe the brackets on the wall using nuts M8 or another adapted fixation.

Caution : Make sure that fixation is strong enough and adapted to the weight of the gas air curtain.

Fixe the air curtain under the brackets using chains or rods (not supplied).

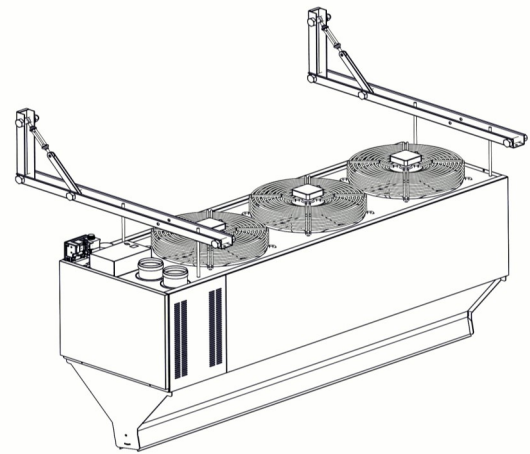

4- FLUE CONNECTION

4-1 General information

During the installation and maintenance you must be sure that :

- Combustion air inlet and fumes evacuation are not blocked.
- While installing a concentric fumes evacuation check that the concentric pipes (fresh air inlet and fumes evacuation) are separate and sealed. The junctions must be sealed and rigid.
- Make sure not to damage the connector seals when assembling the conduits onto the device, check the sealing after assembly.
- The assembly of the conduits must be carried out so that no water can penetrate into the device, due to the electrical risk. For this purpose, please use a purge T-piece and a condensate recover.
- For greater lengths, it is essential to provide a condensate recover; this also applies to assemblies using cups.

4-2 Connection of sealed roof chimney type B22

The combustion air is taken directly in the room and the evacuation of the smoke is made vertically through the roof.

Standard connection :

- 1 T-piece with a sealed plug (1)
- 1 roof terminal (2)
- 1 sealed elbow

The minimum height of the roof chimney must be same as the ridge of the roof.

- For model YAC H 35 and 45 the standard connection is made in diameter 100.

It's possible to extend or deviate the roof chimney using accessories such as elbows and additional lengths (0.5m or 1m).

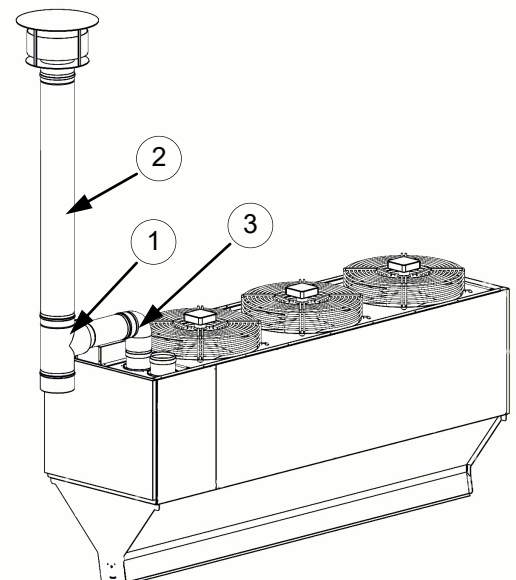

CAUTION

The local of the installation must be well ventilated, fresh air required for combustion must be minimum 100 m³/h per unit. The diameter of smoke pipe must be at least equal to the outlet diameter of the gas unit (use only approved connection elements). Smoke pipe can be only vertical or at a maximum of 45°. Total length of the roof chimney must not exceed 6 m, taking into account that an elbow 90° or 45° = 1 m of length. If the outside part of conduit is more than 2 meters it must be insulated.

4-3 Concentric connection

Wall duct type C12 :

The air inlet and the smoke exhaust pipes are horizontal towards the outside.

Caution: for concentric wall connection, the mounting must be realized with a 2° slope away from the unit.

Standard connection :

- 2 Sealed elbows of 90° (1)
- 1 Mono-tube sealed extension (2),
- 2 Mono-tube sealed extensions (3),
- 1 wall terminal (4)

For model YAC H 35 and 45 the diameter of a standard connection is 100/150 mm

It's possible to extend or deviate the roof chimney using accessories such as elbows and additional lengths (0.5m or 1m).

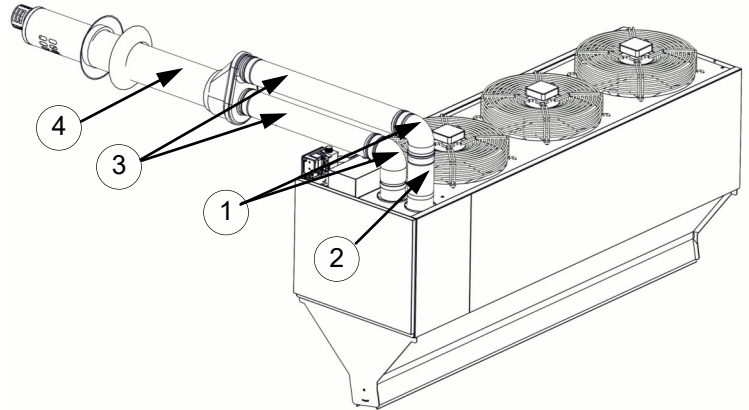

Roof duct type C32 :

The air inlet and the smoke exhaust pipes are vertical towards the outside

Standard connection :

- 2 Sealed extensions (1)
 - 1 roof terminal (2).
- For model YAC H 35 and 45 the diameter of a standard connection is 100/150.

It's possible to extend or deviate the roof chimney using accessories such as elbows and additional lengths (0.5m or 1m).

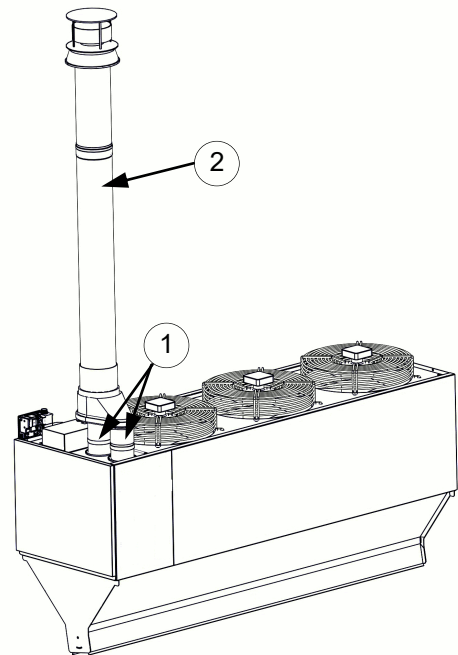

For perfect sealing of fume conduit pipes and for easy assembling it's necessary to use a lubricant (not aggressive, for a sealed gasket, for ex., soapy water).

CAUTION

The connections must be sealed and rigid. The diameter of smoke pipe must be at least equal to the outlet diameter of the gas unit (use only approved connection elements). Total length of the roof chimney must not exceed 6 m, taking into account that an elbow 90° or 45° = 1 m of length. If the outside part of conduit is more than 2 meters it must be insulated.

5- ELECTRICAL WIRING

Electrical connection must be carried out by a qualified professional person in accordance with all norms and rules of the country.

- The gas air curtain must be grounded according to the security norms and rules (see norms C15-100). It must be absolutely done as it's a fundamental rule of security. In the case of doubts, a qualified professional person must control the electrical connection. It's not the responsibility of a producer if there are damages because of wrong electrical wiring or if the devices are not grounded.
- A professional person must control that the electrical connection is in accordance with a maximum absorbed power per unit (check the data on the mark plate of the unit). Take care of a diameter of cables which must be adapted to the adsorbed power of the unit.

5-1 Electrical diagram for YAC35H

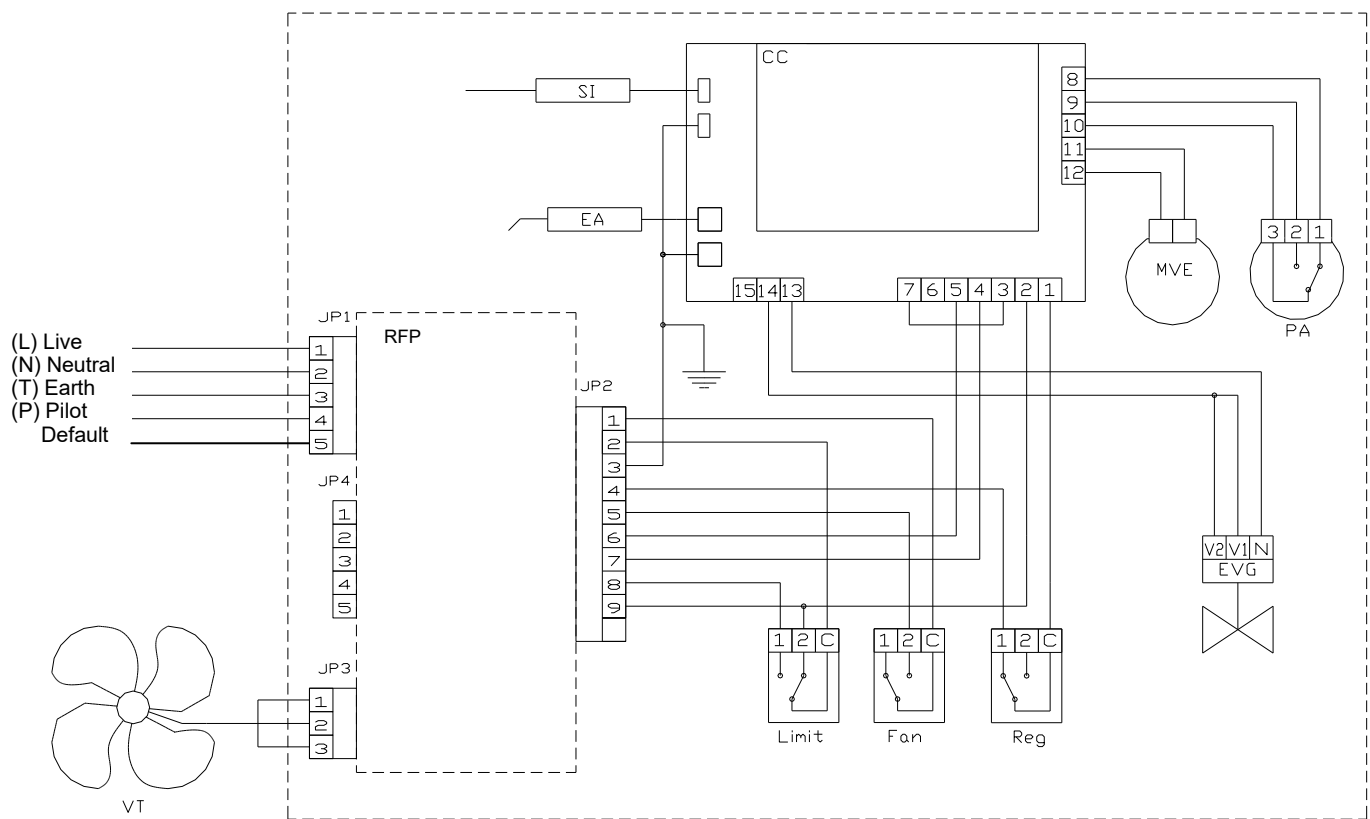

VT	Blowing fan
RFP	Pilot wire receiver
Limit	Overheat airstat with reset
Fan	Fan airstat
Reg	Burner regulation airstat
CC	Control box with isolation transformer

MVE	Smoke extractor
PA	Burner air pressure switch
SI	Ionization sensor
EA	Ignition electrode
EVG	Gas valve

In normal operation, never stop the unit by cutting off the power supply, wait the shutdown of the fan.

Pilot wire card (RFP5)

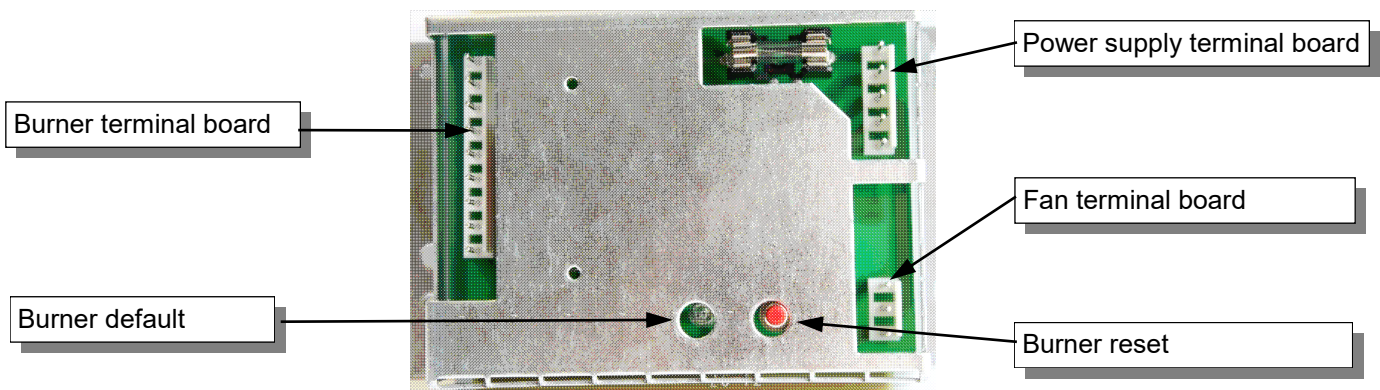

5-2 Electrical diagram for YAC45H

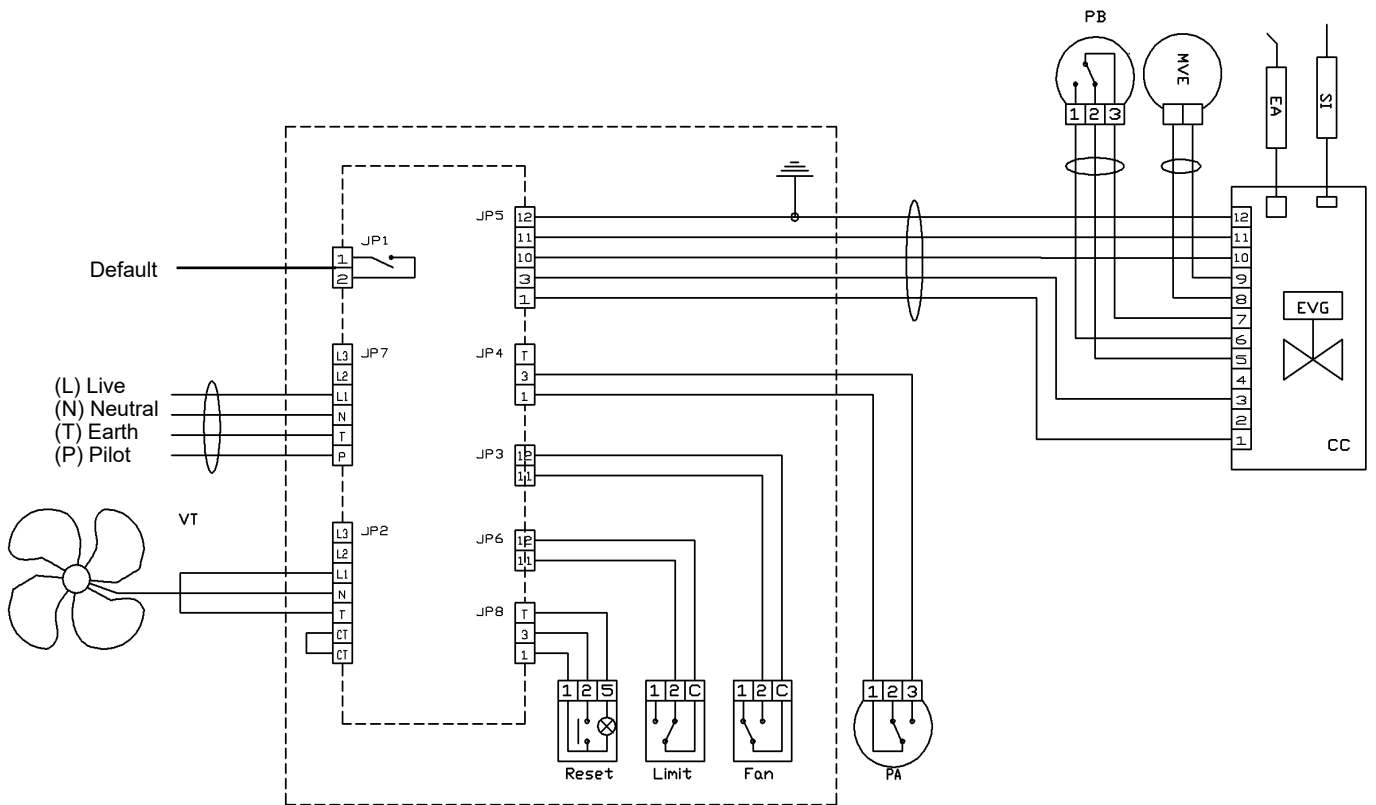

Electrical connection card (RFP6)

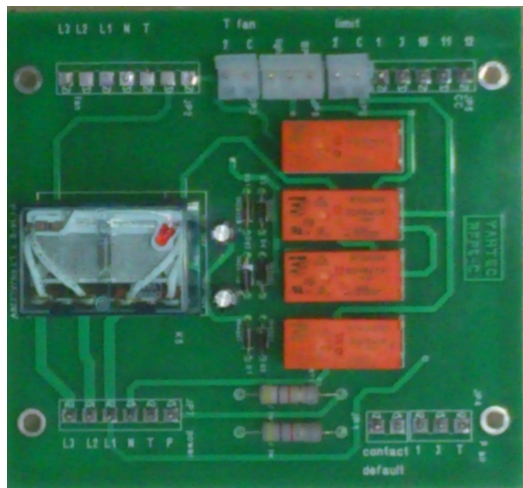

6- GAS CIRCUIT

6-1 Changing of gas

The unit heaters are equipped with atmospheric gas torch burners, permitting the use of Natural gas G20, Natural gas G25 and Propane.

The combustion ports are engineered so as to ensure very good stability of the flame without separation or return towards the injectors.

THE SERVICE VISITS MUST BE CARRIED OUT BY A QUALIFIED PROFESSIONAL PERSON

Changing of gas is carried out in the following manner :

- 1- Disconnect the electrical supply connector and close the gas inlet.
- 2- Remove the door of a burner compartment, after that unscrew the gas line fixing nut of a ramp (Rep. 2). Unscrew four fixing screws of a burner block (Rep.3).
- 3- Get out the burner block, then dismantle an injectors ramp (Rep.4) maintained by 3 screws.
- 4- Change the injectors (check the adjustment table).
- 5- Put new injectors (Rep.5) changing the seals (Rep.6) and making sure concerning seals, **the injectors must be installed dry.**
- 6 - Reassemble the ramp of injectors onto the burner block, connect the gas line to the burner block , **replacing the seal.**
- 7- **Check the sealing after assembly.**
- 8- Adjust the gas ramp pressure on the regulator.

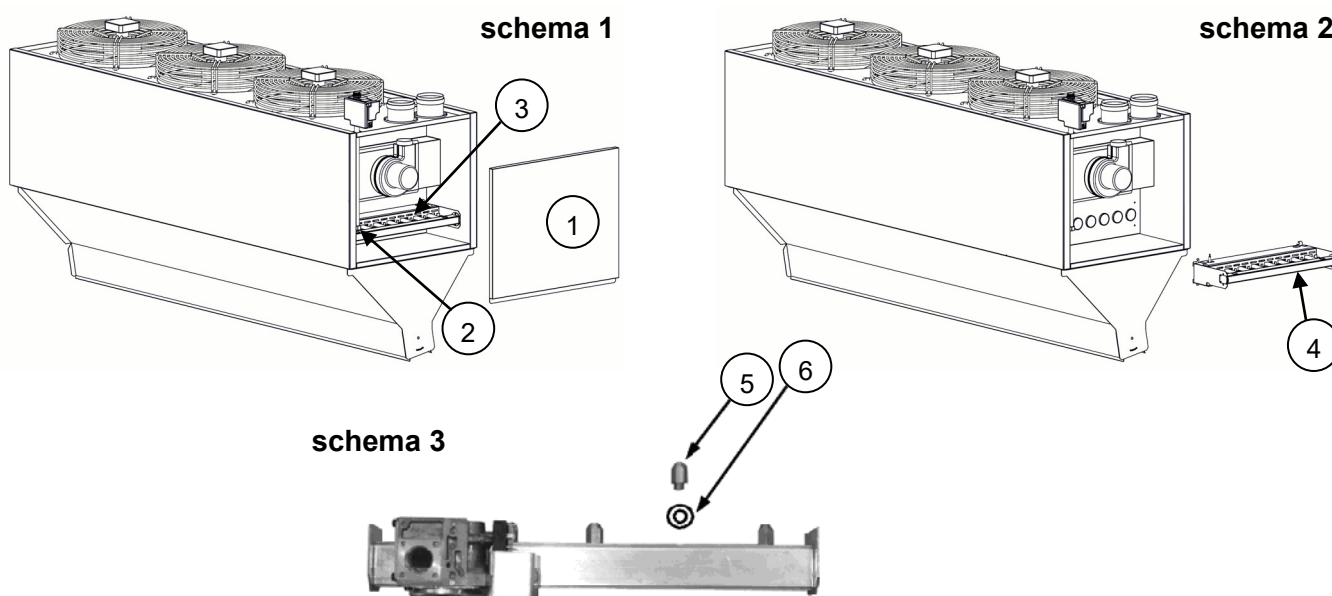

CAUTION : This operation must be done with the gas and electricity supplies cut off.

The adjustment of the gas pressure is made with the burner running.

Adjusting the gas pressure is done in the following manner :

- 1- Open the solenoid valve pressure regulating protection screw(1)
- 2- Unscrew the pressure alimentation test point (2) and control.
- 3- Unscrew the pressure injectors test point (3), connect the pressure gauge
- 4- Adjust the ramp pressure (3) in accordance with the adjusting table (page 11)
- 5- After adjustment, do not forget to put the protective screw pressure and close the pressure test point.

Attention : always check for sealing after adjusting

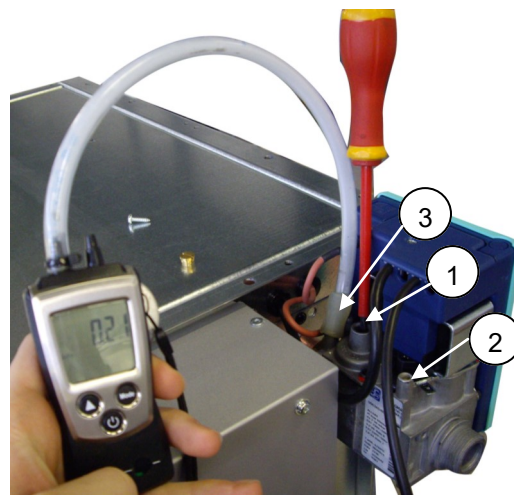

6-2 Valve adjustment table

Types	Adjustment for G20			Adjustment for G25			Adjustment for G31		
	Regulator pressure	Gas ramp injectors	Washer extractor	Regulator pressure	Gas ramp injectors	Washer extractor	Regulator pressure	Gas ramp injectors	Washer extractor
YAC 35 H	9.5 mBar	8 x AL 2.20	30	12.6 mBar	8 x AL 2.20	30	27 mBar	8 x AL 1.10	30
YAC 45 H	9.5 mbar	8 x AL 2.20	30	12.6 mBar	8 x AL 2.20	30	27 mBar	8 x AL 1.30	30

The gas pressure of injectors can change according to the pressure supply.
It's to control the outlet gas valve pressure and adjust it according to the valve adjustment table (here above).

6-3 Gas connection

A precise engineering study must be carried out on the diameters of the piping depending on the nature of the gas flow and the length of the piping.

Make sure that the pressure drops in the piping do not exceed 5 % of the supply pressure.

The gas connections must be carried out in conformity with the requirements concerning interior installations regardless of the type of gas.

Gas air curtains functioning on the inlet pressure from 20 to 50 mBar for Natural gas and from 37 to 50 mBar for Propane gas (pressure supply can change according to the country).

1/ The gas supply network pressure corresponds to the entry pressure of the device:

- in this case, connect each device with a dam valve item 1 and the gas filter item 2.

2/ The gas supply network pressure is higher than the intake pressure of the device:

- in this case, connect each device with a dam valve item 1, a gas filter item 2 and a pressure regulator item 2, to reduce the supply pressure to the unit heater.

CAUTION Any supply pressure which is higher than the maximum intake pressure tolerated by the gas solenoid valve will cause irreparable damage to that solenoid valve.

To connect the unit heater to the gas network, use the union item 4 with the seal item 5 delivered with the device. **Tighten the union onto the network before connecting it to the unit heater.**

Check that the gas supply circuit is correctly sealed up to the gas solenoid valve. (see schematic).

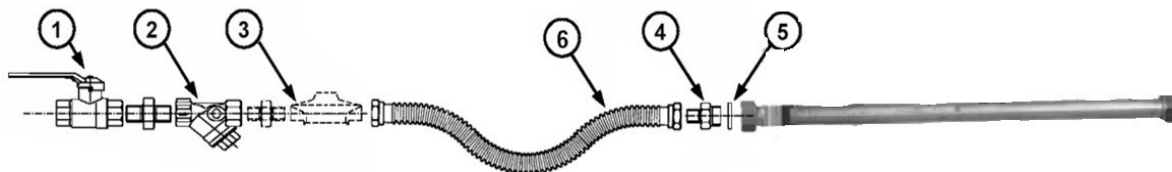

Check the sealing up to the gas solenoid valve input

7– COMMISSIONING OF GAS AIR CURTAIN

7-1 Operating principal

1– For the commissioning of the device, turn the regulation to demand and switch a door sensor on. The control and safety box check the contact of the air pressure switch after that the fume extractor goes into operation. Its functioning is controlled by the differential air pressure switch (PA) which will prevent the functioning of the control and safety box in the case of the lack of air.

2- During the commissioning of the air curtain the fans start and their air flow is controlled by the air pressure switch (PV). If the air flow is sufficient a burner control and safety box is powered.

3– If the mix of air/gas is not ignited and the flame is not detected by the ionization sensor the control and safety box makes the second attempt then changes to safety position.

5– In the case of a fan malfunctioning or air inlet obstruction the air pressure switch (PV) cuts off the burner of the gas air curtain.

If the temperature exceeds 90 °C the excess heat safety thermostat cuts off burner of the gas air curtain.

6– When the air curtain is cut off the fan airstat can trigger the fans if the air temperature around the heat exchanger is higher than the fan airstat set up (set up at 35°C) .

CAUTION :

Never stop the device before the fan has totally stopped. The lack of cooling can necessitate the excess heating airstat to be reset and can damage the heat exchanger over the long term.

7-2 Bill of material

YAC35H

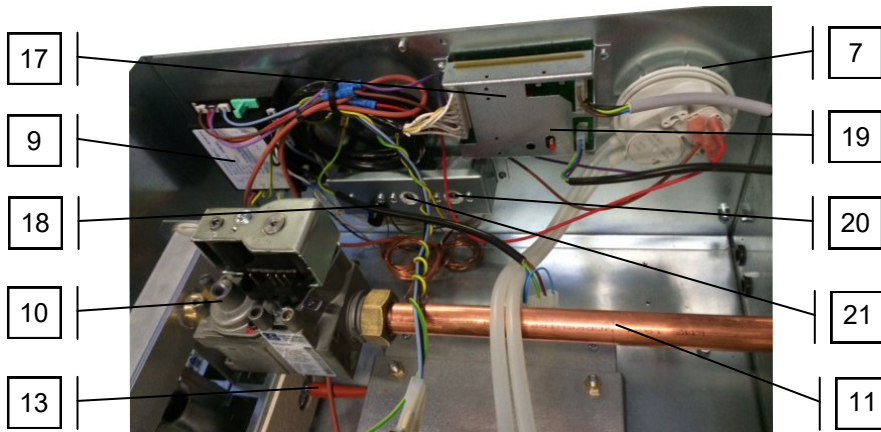
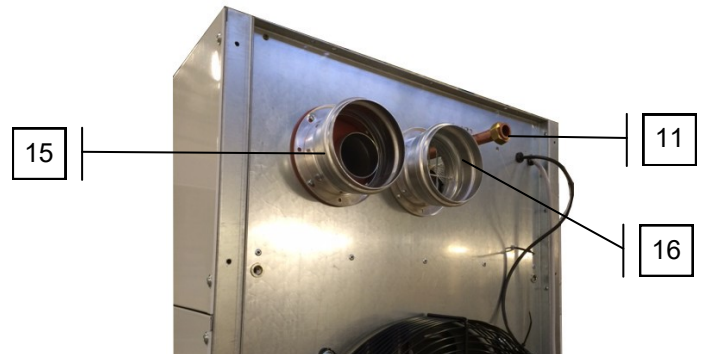
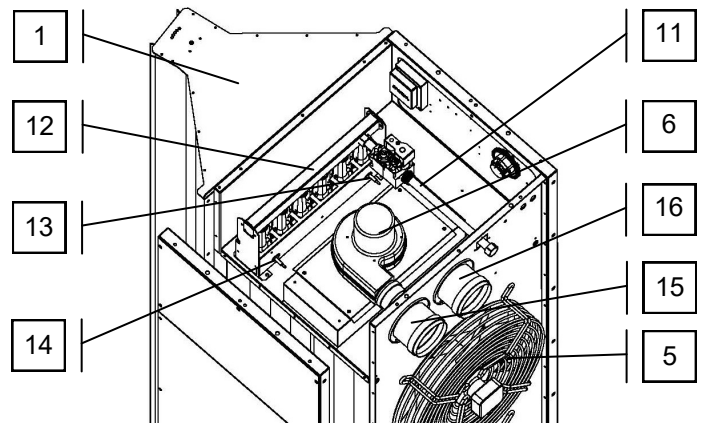
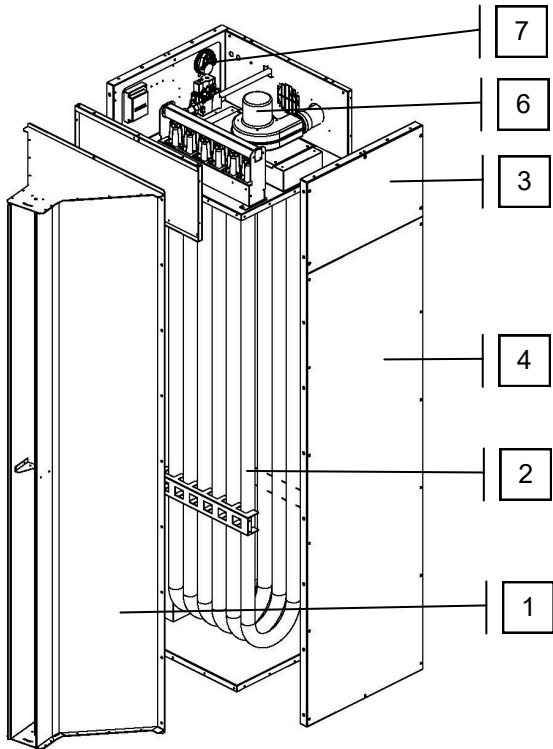

N°	Description	YAC35H
1	Diffuser	-
2	Tubular heat exchanger	SEECHYAC154230
3	Burner body sheet metal	YN22-V-T00-L00
4	Body sheet metal	YN20-C-T00-L20
5	Blowing fan	ATE802S
6	Smoke extractor	ATE013
7	Lack of air pressure switch	ATE204
8	Fan safety pressure switch (blowing control)	ATE328
9	Control box	ATE332
10	Gas valve	GAZ0011
11	Gas pipe	GAZ0109
12	Gas burner	-
13	Ignition electrode	ATE021
14	Ionization sensor	ATE022
15	Fumes outlet	ATE004
16	Combustion air inlet	ATE004
17	Pilot wire card RFP5	ATE521
18	Overheating safety thermostat	ATE147
19	Burner reset	-
20	Burner regulation thermostat	ATE146
21	Fan thermostat	ATE146

7-2 Bill of material

YAC45H

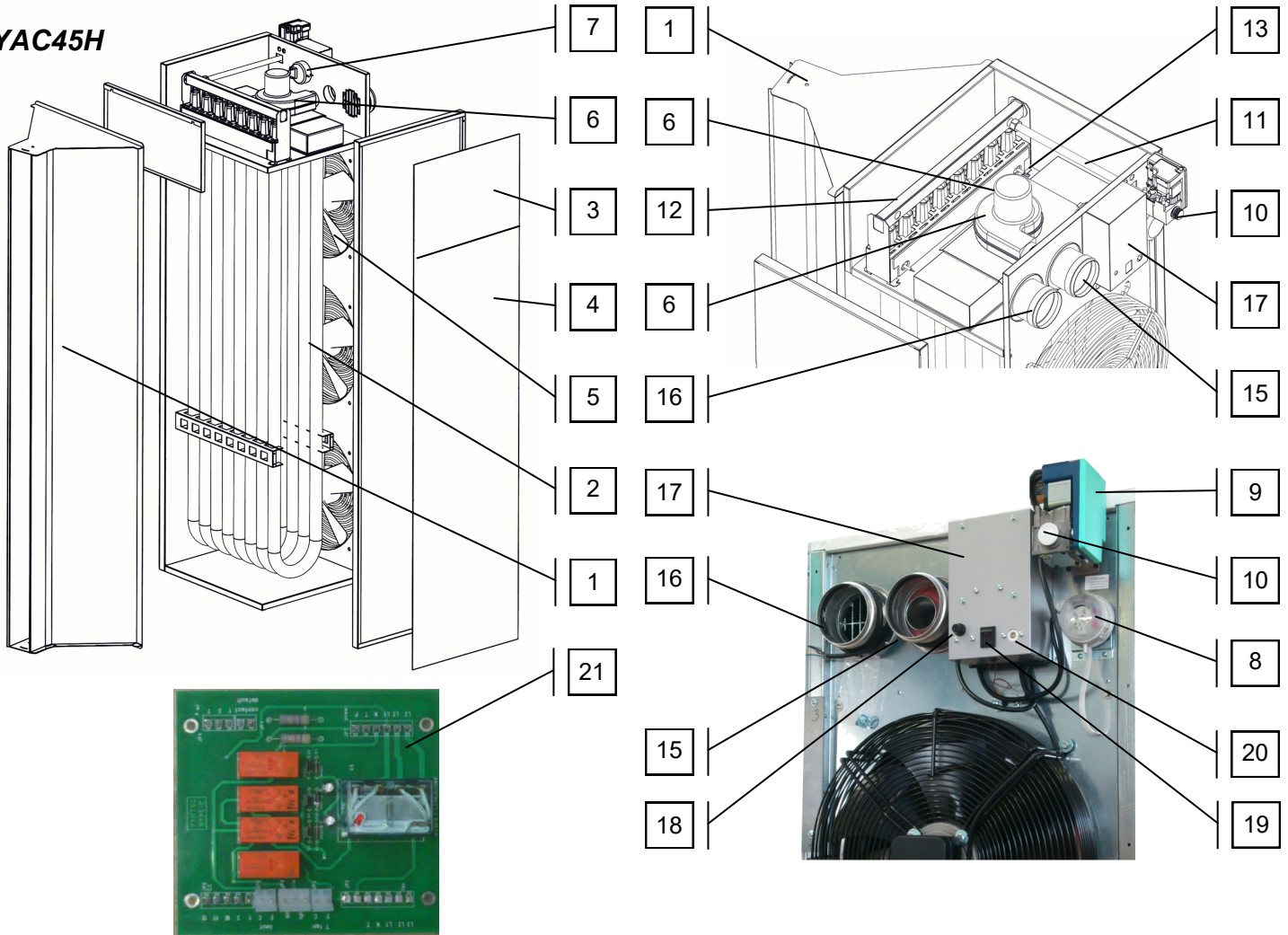

N°	Description	YAC45H
1	Diffuser	-
2	Tubular heat exchanger	SEECHYAC205040
3	Burner body sheet metal	YN22-V-T00-L00
4	Body sheet metal	YN20-C-T00-L20
5	Blowing fan	ATE803S
6	Smoke extractor	ATE013
7	Lack of air pressure switch	ATE204
8	Fan safety pressure switch (blowing control)	ATE328
9	Control box	UTC0410
10	Gas valve	GAZ0011
11	Gas pipe	GAZ0109
12	Gas burner	-
13	Ignition electrode	ATE021
14	Ionization sensor	ATE022
15	Fumes outlet	ATE004
16	Combustion air inlet	ATE004
17	Electrical box	SECEYAC156050
18	Overheating safety thermostat	ATE147
19	Burner reset	-
20	Burner regulation thermostat	ATE146
21	Electrical connection card RFP6	ATE500

8- TROUBLESHOOTING

In case of problems, make sure that the conditions required prior to operating the unit heater are present. If the control box is in the safety position (with the burner defect indicator lamp lighted up), reset it.

CAUTION : All electrical or mechanical operations must be carried out when the electrical supply is cut off and the gas supply is closed.

Defects	Causes	Solutions
The device doesn't start	<ul style="list-style-type: none"> - Incorrect wiring - No voltage -The ambient thermostat is not triggered - The pilot wire receiver switch is not in the automatic position -Excess heat safety airstat triggered. 	<ul style="list-style-type: none"> - Check the wiring - Verify the electrical supply - Increase the setting point of the ambient thermostat - Check the position of the receiver switch in the unit heater - Reset the airstat
The burner preventilates continuously	<ul style="list-style-type: none"> -Extractor defective -Air pressure switch disconnected -Air pressure switch defective 	<ul style="list-style-type: none"> - Replace the extractor - Reconnect the pressure air pipes - Replace the air pressure switch
The ignition electrode is making sparks, the burner lights, the control box goes into safety position (burner defect indicator lamp lighted up)	<ul style="list-style-type: none"> -Gas solenoid valve defective -Control box defective -Ionisation sensor out of adjustment or defective -Air in the piping -No gas 	<ul style="list-style-type: none"> - Replace it - Replace it - Adjust it or replace it - Bleed the piping - Check the pressure
The device goes into safety position during operation (red light comes on)	<ul style="list-style-type: none"> -Gas supply interrupted 	<ul style="list-style-type: none"> - Reset by pressing the red push button on the control box
Cold air when starting	<ul style="list-style-type: none"> -Incorrect adjustment of internal thermostat 	<ul style="list-style-type: none"> - Check the adjustment of the ventilation thermostat (adjustment 35°C)
The device doesn't heat sufficiently	<ul style="list-style-type: none"> -Incorrect placing of the thermostat -Incorrect adjustment of the thermostat -Insufficient gas pressure -Injectors are unsuitable 	<ul style="list-style-type: none"> - Modify its location - Check the thermostat - Check the gas supply pressure - Check that the injectors are correctly selected and replace them if necessary.

9- RECOMMENDATIONS FOR THE USER

9-1 Maintenance

Correct and regular use and maintenance of the unit heater will determine rational and efficient operation, minimum consumption as well as long life.

The maintenance must be done with the device cold, with the gas and electricity supplies cut off.

These service visits must be carried out by a qualified professional person

Parts	Maintenance operations
Gas air curtain	Check the correct functioning of all the safety devices.
Heat exchanger, smoke extractor and venturi	Get access to the heat exchanger by disassembling the burner and smoke boxes, clean it. Clean the extractor and the venturi via the rear smoke connection.
Fan	Clean with compressed air
Smoke conduit	Disassemble the conduit and sweep it out.
Bodywork and diffusor	Clean using a duster
Burner torches	Disassemble the burner ramp, check their condition and clean them
Injectors	Clean the gas injectors
Ionisation sensor and electrodes	Check their condition, change them if necessary.
Gas filter	Disassemble the dirty cartridge and clean it with compressed air

9-2 Specific instructions :

- Never obstruct the evacuation of the smoke and the intake of new air.
- Never cut off the electricity before the complete cooling of the heat exchange of the gas air curtain.
- Never make any modifications to the adjustments which have been carried out by the qualified professional person.

- Warn the after-sales technician when there is a change of gas, of gas pressure or a modification of the power supply voltage.

You are strongly recommended to take out a maintenance contract: "see with your installer".

What should be done in case of problems ?

PROBLEMS	SOLUTION
<i>Smell of gas</i>	<i>- Close the external gas valve and the electrical supply then warn the maintenance technician.</i>
<i>The burner stays in safety position</i>	<i>- Press the reset button of the burner located on the thermostat control box. - If the problem persists, contact the after-sales technician.</i>



YAHTEC

36 rue Pascal
77100 Meaux
France
Tél. : (33) 01.60.24.41.86
Fax : (33) 01.64.34.24.03